

**Report of the Asok Kumar Committee  
for the Review of The  
Civil Aviation Requirements (CAR)  
for Persons with Disabilities**

**October, 2012**

**Ministry of Civil Aviation**

**New Delhi**

**Report of the Asok Kumar Committee for the Review of The  
CAR for Persons with Disabilities**

**Contents**

Introduction	
Executive Summary	
Report	Review of Existing CAR on Carriage of Persons with Disability or Reduced Mobility.  Need for redefining 'Disabled person' Allocation of Responsibilities between airports and airlines Accessibility of Ticketing System Complaint Redress System Airports Facilities and Equipment Review of the CAR and Recommendations
Annexure 1	International Best Practices on Interaction with Person with Disabilities
Annexure 2	Training
Annexure 3	Guidance Material on Accessible Airport Infrastructure
Annexure 4	Security Process
Annexure 5	Funding of costs with respect to implementation of regulations
Annexure 6	Implementation Plan
Annexure 7	Minutes of the meetings of the committee

### **Introduction**

Ministry of Civil Aviation has constituted a committee on 22<sup>nd</sup> March 2012 to look into various issues relating to improving the air travel by persons with disabilities and reduced mobility. Even though air travel has become ubiquitous, persons with disabilities continue to face barriers during their travel. Air travelers with disabilities are entitled to the same high quality service as all other passengers. While some positive steps such as the introduction of Civil Aviation Requirements on Carriage by Air of Persons with Disability and/or Persons with Reduced Mobility (“CAR”) have been taken, the experience on the ground remains at a low level. It is observed that the CAR is inadequate in terms of coverage, inefficient in terms of allocation of responsibilities between the stakeholders and is lacking in the area of necessary mechanisms for enforcement. Given the above, it is considered necessary to amend the CAR to ensure that persons with disabilities can have access to, and enjoy air travel on an equal basis with others, without discrimination, with dignity, and in safety and comfort.

The following members constituted the Committee:

1. Sh. G. Asok Kumar, Joint Secretary, Ministry of Civil Aviation (Chairman)
2. Three representatives of organizations working for Persons with reduced mobility/ disabilities:
  - a. Rahul Cherian Jacob Inclusive Planet Centre for Disability Law and Policy
  - b. Shivani Gupta, Disability Rights Group
  - c. Anjlee Agarwal, Samarthyam
3. Mr. Shekhar Borker, Board Member, National Trust (Ministry of Social Justice and Empowerment)
4. Ms. Puja Jindal, Director, MoCA
5. Mr R.N.Dhoke, Addl COSCA, BCAS
6. Sh. Lalit Gupta, DDG, DGCA
7. Sh S.C.Sharma, ED, Operations, AAI
8. One Representative of a private Airport Operator (DIAL)
9. One representative of AirIndia (National carrier) , Indigo and Jet Airways (Private carriers)

The terms of reference of the Committee were as under:

- i) To review the existing CAR on “Carriage of Persons of disability and reduced mobility” by air

- ii) To study best practices in the world, latest UN /ICAO guidelines on carriage of persons with disability.
- iii) Suggestions for improvement of design of websites, accessories and facilities/ infrastructure etc specially meant to facilitate comfortable air travel for the persons of reduced mobility and disability.

The committee met three times and formed three subcommittees to make indepth study of the ToRs. There were many online discussions. The committee acknowledges the positive contribution and suggestions from the following domain experts in preparing the report:

1. Mr. A.K. Mittal, President, All India Confederation of the Blind;
2. Maj. Gen. (Retd.) Ian Cardozo, Chairman, Rehabilitation Council of India, Ministry of Social Justice and Empowerment;
3. Ms. Janaki Venkatasubramanian;
4. Ms. Merry Barua, Action for Autism;
5. Mr. Rajive Raturi, Director, Disability Rights Initiative, Human Rights Law Network;
6. Ms. Reshma Val, Mental Health Self-Advocate & Researcher at The Red Door under Mind Arcs;
7. Ms. Ritika Sahni, Founder Trustee, Trinayani;
8. Dr. Sudha Kaul, Vice Chairperson of the Indian Institute of Cerebral Palsy;
9. Prof V.S. Mallar, Chair Professor (M.K. Nambiar Chair on Constitutional Law), National Law School of India University, Bangalore;
10. Dr. V. Vijaykumar, Vice Chancellor, Ambedkar Law College, Chennai;
11. Ms Vaishnavi Jayakumar;
12. Mr. Vineet Subramani, Advocate, Madras High Court; and
13. Mr. Zamir Dhale, Sr. Advocacy Officer, Sense International.
14. Mr. RP Sahi, Consultant, Ministry of Civil Aviation

The Committee examined the existing requirements in the form of CAR Section 3 Series M Part I which was last amended on 26 March, 2009. In the following paragraphs, the suggestions and recommendations are indicated as a result of detailed discussions among the committee members and experience of the passengers with disabilities.

In addition, funding for the implementation of the regulations has been discussed. It is also seen that the Mechanism for addressing the complaints does not exist in the absence of which the stakeholders responsible for providing facilities and extending necessary courtesy are often found wanting. This report addresses this issue and recommends a redressal mechanism. During the course of deliberation of the committee it was seen that some advance countries have made considerable progress in establishing procedures for the social issues of persons with disabilities of various kinds. This report contains

detailed guidelines on international best practices, which when adopted, will go a long way in providing dignified air travel to persons with disability.

A significant compilation of information on the subject of Accessible Airport Infrastructure as standards of universal access to airport terminal buildings has also been included in this report as Annexure 3 which will be a useful guidelines material.

In light of the large scale changes that are required particularly with respect to allocation of responsibilities between airports and airlines, it is recommended that the existing CAR is suitably amended.

The implementation of the amended CAR must be completed in a phased manner over the next 3 years starting with the larger airports and moving to smaller airports.

\*\*\*

### **Executive Summary**

Ministry of Civil Aviation constituted a Committee to look into the issues of improving the air travel by persons with disabilities and reduced mobility. The committee which was headed by Joint Secretary, Ministry of Civil Aviation, had representation from organizations working for the benefit of Persons with Reduced Mobility (PRM) and disability. In addition, the committee had senior officials from Ministry of Civil aviation, DGCA, Airports Authority of India and JV airports and airlines as members. The committee was also assisted by large number of experts whose valuable contribution has been acknowledged.

It has been recommend that allocation of responsibility between airports and airlines should be clearly defined to avoid delays and inconveniences/hardships to PRMs arising due to lack of communication between service providers. It has also been suggested that the equipment and other facilities should be standardized in consultation with Department of Disabilities Affairs. Internal audits should be introduced to ensure that assistive devices are available in good condition and handling persons are properly trained in their use. This aspect should also be overseen by DGCA. Responsibilities also need to be clearly defined for each stakeholder namely responsibility of the airlines, their agents and ticketing website for ticketing, airport operator for providing a helpdesk and assisting the passenger on arrival at the airport, responsibility of airline for check-in, responsibility of CISF for security check etc.

The report highlights some important areas which are not covered in the existing CAR. These include accessibility of ticketing system and complaints and redress mechanism. A 'Complaints Resolution Officer' to deal with issues relating to PRMs has been recommended for each airport. It has also been suggested that Ombudsman be appointed for settlement of complaints between complainant and airport/airline through conciliation and mediation. The report covers the airport facilities and equipment required in an exhaustive manner. It covers accessible routes and passageways, wayfinding, signage, automated kiosks, accessible telecommunication systems/announcements, arrival/departure monitors, seating areas and guidance for service animals.

The committee reviewed the CAR existing on the subject and has made several recommendations for amendment in the CAR. It is suggested that the definition of persons with reduced mobility should include such persons who require assistance in air travel, for example, persons with hearing and vision impairment, persons with autism etc., who have no visible impairment but still require facilitation at the airport and in the aircraft. The committee has suggested standardization of training, standard operating procedures, need for sufficient oversight by authorities, need for clarity on requirement of medical clearance by passengers, standardization of equipment at airports and on aircraft,

proper training of security checking personnel and need for more clarity on seating arrangement to PRMs. It is suggested that curb-side assistance kiosks should be mandated and guidelines should be issued on provision of priority tags for passengers on wheelchairs. It recommends mandating location of dedicated parking space at airports and for the accessibility of in-flight entertainment system. Safety briefings in aircraft should also be made in sign language for persons who are hard of hearing/deaf. It should also cover emergency evacuation of blind passengers.

The report highlights international best practices on interaction with persons with disabilities, covering separately the interaction with the blind, the deaf and persons with mobility disability etc. It also covers in detail the training procedure including initial and recurrent training.

Significant Recommendations include:

- Revision of CAR on Carriage by Air of Persons with Disabilities in a time bound manner;
- Ensure compliance of recommendations within 3 years at major airports and then at other airports in a phased manner;
- Address a suggested funding mechanism for meeting cost of implementation;
- Define allocation of responsibilities for airlines, airports and others for their respective roles in providing facilities to persons with disabilities;
- Standardization of equipment like wheelchairs and facilities designed for PRMs;
- Establishment of Standard Operating Procedures for all service providers and adequate training of their staff;
- Web enabled booking, in-flight briefing and evacuation of such persons;
- Implement a mechanism for grievance redressal.
- Airlines and airports declare their policy on facilities provided to PRMs by publishing on their respective websites.

The committee agreed that there will be substantial cost of implementation of the suggested recommendations and has suggested some options for recovering the cost. These include the airport operators and airlines bearing the cost of providing the service. Alternatively, a small charge may be levied on each passenger of an airline using an airport. The fund so collected can then be distributed to the airlines and airports in proportion to the number of passengers with disabilities carried by them. The Ministry of Social Justice and Empowerment or Ministry of Civil Aviation may also consider funding the implementation of the regulations. The committee has suggested that a timeframe for taking decision on the recommendations must be evolved. The committee has also suggested that recommendations may be implemented in the category of airport having the largest number of passengers needing assistance and in the later phase, these may be implemented at other airports as well. The implementation of the amended CAR must be completed in a phased manner over the next 3 years starting with the larger airports and moving to smaller airports.

## Report

### **Review of Existing CAR on Carriage of Persons with Disability or Reduced Mobility**

#### **1. Need for Re-defining the ‘disabled person’ or person with reduced mobility**

- 1.1 As per paragraph 3.1 of the CAR a “disabled person” is defined as any person whose *mobility* when using transport is reduced due to physical disability, intellectual disability or impairment, or any other cause of disability, or age. It must be recognized that not all persons with disabilities who require assistance in relation to air travel are persons with mobility impairment. Some such examples are people who are hard of hearing, people who have low vision, people with autism, etc., who have no visible impairment but still require assistance/facilitation.
- 1.2 The committee suggests that definition of “disabled person” must be made wider and more comprehensive and inclusive of person with reduced mobility, rather than have two different definitions. The following definition of “disabled person” based on the United Nations Convention on the Rights of Persons with Disabilities and the US Title 14 Part 382 “Nondiscrimination on the basis of disability in air travel” may be used.

**“Person with disability”** means any individual who has, a physical, mental, intellectual or sensory impairment that, on a permanent or temporary basis, due to age or otherwise, limits one or more major life activities and as a result of such impairment needs appropriate attention and adaptation to his or her particular needs of the service made available to all passengers.

As used in this definition, the phrase: (a) “impairment” includes: (1) any physiological disorder or condition, cosmetic disfigurement, or anatomical loss affecting one or more of the following body systems: neurological, musculoskeletal, sense organs, respiratory including speech organs, cardiovascular, reproductive, digestive, genitourinary, hemic and lymphatic, skin, and endocrine; or (2) any mental or psychological condition, such as intellectual disability, organic brain syndrome, psycho-social disability, and invisible disabilities such as autism and learning disabilities.

The term “impairment” includes, but is not limited to, (a) conditions such as orthopedic, visual, hearing, speech, deaf-blindness and other impairments; cerebral palsy, epilepsy, muscular dystrophy, multiple sclerosis and (b) diseases such as cancer, heart disease, etc.

“Major life activities” means functions such as caring for one’s self, performing manual tasks, walking, standing, bending, kneeling, seeing, hearing, speaking, breathing, learning, and working.<sup>1</sup>

- 1.3 It must be noted that not all people identify themselves as disabled despite significant impairment and incapacitation (the elderly for example may resist such nomenclature) and services extended to them must be proffered with sensitivity keeping in mind whether disability is being perceived or assumed.
- 1.4 Moreover, specific requirements may be needed by passengers with diverse conditions – for example pregnancy. It is therefore advised to make the CAR more inclusive by titling it “Carriage of Persons with Special Needs, Impairments, or Disabilities.

## **2. Allocation of responsibility between airports and airlines**

At present the allocation of responsibility between the airports and the airlines under the CAR is suboptimal from the perspective of efficiency, accountability and from the perspective of seamless provision of services. While the on-ground infrastructure facilities such as ambulifts are to be provided by airports, on ground assistance is to be provided by airlines. This often leads to the airports and the airlines “passing the buck” when it comes to providing the facilities. The disadvantages of the current structure are given below:

### **2.1 Infrastructure owned by airports/contracted ground service agencies and on-ground services provided by airlines**

Under the present CAR airport infrastructure such as ambulifts are to be procured by airports and airlines have to lease this equipment from airports on as-required basis. As a result it is seen that ambulifts are not made available to passengers promptly and a heavy amount is charged from the passenger for provision of ambulift. It is seen that at times there is a lot of delay which arises due to the miscommunication between the airports and the airlines with respect to the assistance required.

After discussion it was suggested that since all airlines operating at an airport may not have an ambulift each, the present practice of the airport operator owning the ambulift equipment should continue, provided the procedures involved are documented and are strictly complied with. Efforts should be made to achieve the goal of every airport having a minimum of one ambulift and in airports where the traffic is higher, additional ambulifts must be procured such that no passenger has to wait for more than 30 minutes

---

<sup>1</sup> In this document, unless otherwise specified, the term “person with disability” is used to mean the people covered under this definition.

to get the use of an ambulift. While booking the ticket, the requirement of an ambulift must have been specified, and the airline must make a request for the ambulift to the airport operator at least 24 hours in advance of the requirement. All ticket booking facilities of all airlines and ticketing websites must provide the option for passengers to request for ambulifts and this information must seamlessly be passed on to the concerned airport operator. The confirmation details of the ambulift must be informed to the passenger along with confirmation of the ticket booking via SMS and email.

## **2.2 No standardization of equipment**

Under the present CAR, the assistive equipment at the airport such as wheelchairs are to be procured by the airlines. It is seen that each airline procures different types of equipment as a result of which there is no standardization of the equipment. This can be avoided if one entity procures all the equipment and the standards built into the tendering process. In this report, committee has recommended elsewhere that all ground handling facilities for persons with reduced mobility be provided by the airport operators. Since all on ground services are to be provided by the airport and not the airlines, the airports should procure all assistive equipment based on a schedule of standardized equipments. The standardization, should be done in consultation with the Department of Disability Affairs in a suitable time frame. The airlines may also procure their own equipment to improve their services.

## **2.3 Lack of accountability**

Due to the current allocation of responsibility between the airlines and the airports, there is a lack of accountability in the event violations occur.

This can be avoided if respective airlines and airport operators have an internal audit system in place to ensure that assistive devices are available and are in good condition and assistance and training are provided in an adequate and proper manner. This can also be overseen by DGCA as the regulator.

## **2.4 Difficulty in training**

The present allocation of responsibilities means that training must be provided at the airports to the staff of each airline. This is not effective and is also more expensive. This can be avoided if the on-ground services at an airport are provided by one entity, in which case training can be given to the staff of that one entity.

The possible solution for this could be to follow the model adopted in the European Union under which all on ground assistance is provided by the airport and not the airlines. The responsibilities of the airlines come in only at the stage of booking the ticket, at check in and on the aircraft. At all other times, the responsibilities of providing

assistance lie with the airport. If any third party subcontractor is appointed for any ground handling by airports/airlines, the primary accountability will be of the airport/airline. The ICAO does not prescribe any specific allocation of responsibilities between the airports and the airlines.

**2.5 Allocation of responsibilities, clearly defining the responsibility of each stakeholder.**

The responsibilities should be allocated in accordance with the following process flow. This is based on Regulation (EC) No. 1107/2006 of the European Parliament<sup>2</sup>.

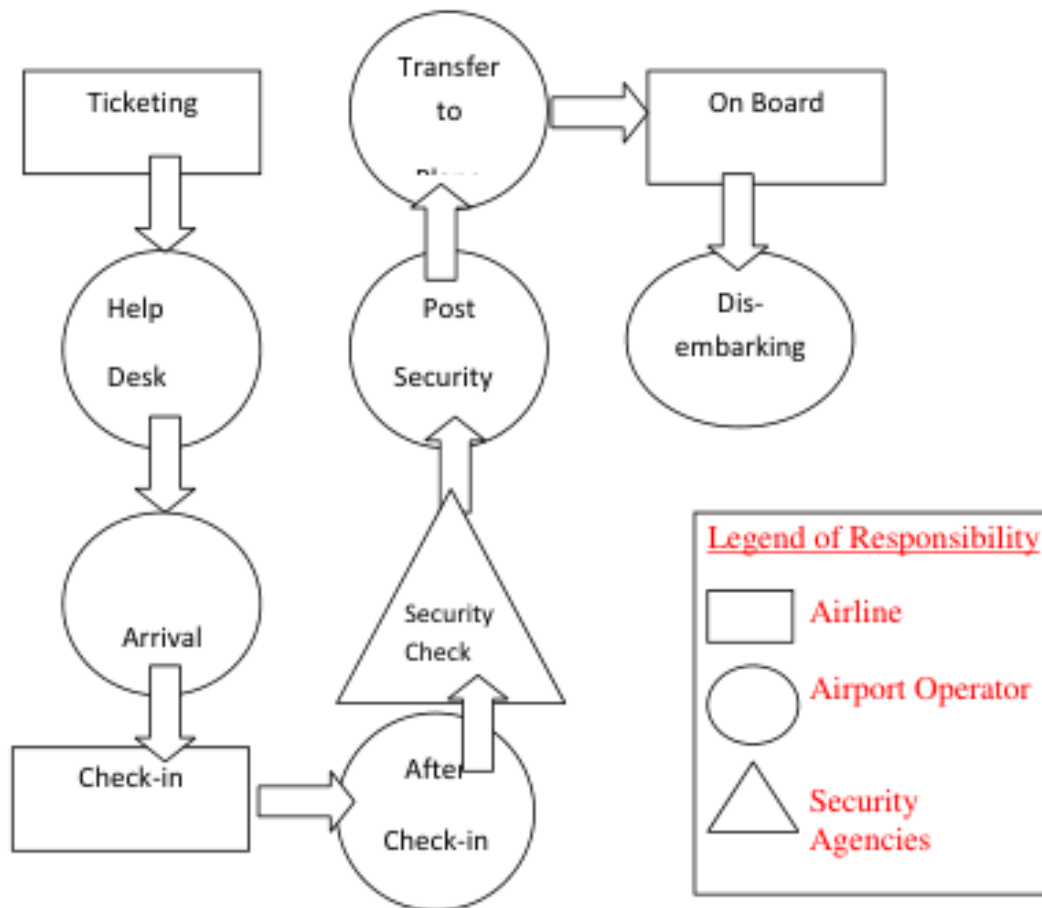

Overview of assistance which may be provided for by each stakeholder based on above process flow is given above. Detailed input on each stage is provided in the subsequent pages.

**2.5.1 Ticketing - Responsibility of the Airlines, their agents and ticketing websites**

- i) All airlines, their agents and ticketing websites must make their websites accessible and compliant with Web Content Accessibility Guidelines (WCAG 2.0)

<sup>2</sup> It must be noted that the EU regulations do not refer to the CISP, which reference has been added by the sub-committee.

- ii) The requisite forms for requesting assistance in advance must be provided on the websites. For tickets booked over telephone, the agent / Interactive Voice Response System (IVRS) making the booking must ask for the relevant information from the passenger. Many airlines do ask for the occupation of a passenger during check-in or might be informed through bookings. Knowing they have the data of their passengers, they could utilize their professional skills especially when there are doctors, therapist, counselors, teachers, social workers, etc who would be travelling and might be able to be of help during rush hours or lack of staff (applicable to all).
- iii) Information requests for on-ground assistance must be forwarded to the relevant airport. If the tickets are bought through agents or ticketing websites, the information for on-board assistance must also be forwarded to the relevant airline.
- iv) SMS/Email confirmation of assistance request to be sent to passenger.

### **2.5.2 Helpdesk -- Responsibility of the airport operator**

- i) A telephonic help desk should be set up to receive assistance requests in advance. This could incorporate sign/language translation relay services.
- ii) Requests for on-board assistance should be communicated to the relevant airline.
- iii) SMS/Email confirmation of assistance request should be sent to passengers.

### **2.5.3 Arrival at airport -- Responsibility of the airport operator**

- i) Curbside assistance kiosks airport may be set up (further details of assistance kiosks given in subsequent pages). Some passengers might wear or carry a 'need or care card' with them. Provision of live assistance and intermediaries, including guides, readers and professional sign language interpreters must be made at the curbside kiosks.
- ii) The assistance kiosk must facilitate movement of persons with disabilities from parking areas to check-in counters by providing qualified/properly trained personnel and necessary assistive aids/equipment. For this purpose the passenger will be required to call the assistance kiosk in advance.
- iii) A system of 'inclusive help' should be provided. Check-in counters can have boards which read 'Are you a passenger willing to help another? Let us know'. Many people travelling alone do take their own initiative to help an elderly person.
- iv) On request, the passenger may be moved to toilet facilities.
- v) For passenger travelling with escort, the escort should be allowed to provide the assistance if requested, including pushing the wheelchair.

- vi) The passenger may be allowed to use own wheelchair all the way to the aircraft if so required by the passenger.

#### **2.5.4 Check-in - Responsibility of the airline**

- i) Priority tags may be provided for checked-in assistive aids and equipment.
- ii) Assistive aids/equipment shall not be sent on conveyor belt.
- iii) Assistive aids/equipment must be loaded last and unloaded first.
- iv) The airlines must not insist that assistive aids/equipment must be checked-in.

#### **2.5.5 After check-in -- Responsibility of the airport**

- i) The passenger may be provided assistance in proceeding from the check-in counter to security check, and to toilet facilities if required.
- ii) If passenger is travelling with escort, the escort may be allowed to provide the assistance including pushing the wheelchair.

#### **2.5.6 Security Check - Responsibility of CISF**

Security checks are a common concern for persons with disabilities because security personnel are not adequately trained in handling such persons. While there is no doubt that security is paramount, the dignity of persons with disabilities must not be violated during the security process. Security screening must be conducted while completely respecting the rights of persons with disabilities. Some of the problems faced by passengers with disability include persons in wheelchairs being asked to stand up, people being asked to remove their clothes so that their prosthetic limbs/calipers can be touched by the security personnel etc.

The best practices to be followed during the security process are given below:

##### **i) Interaction with persons with disabilities**

Screeners shall be trained to:

- a. Be courteous and friendly
- b. Treat everyone fairly and equally
- c. Be respectful throughout the screening process
- d. Assess the needs of person to be screened
- e. Ask, and not assume the type of assistance needed
- f. Provide appropriate screening options.

**(ii) Screening Process**

- a. For passengers using wheelchair or other mobility aid the screening officer shall advise of the screening process that will be required prior to entering the Departure Lounge. Passengers are to advise the screening officer of their condition and if required, request separate screening to avoid passing through a metal detector.
- b. The Screening points should have, full body scanners, chairs and walking aids for semi ambulant walking-aid user.
- c. Full body scanners should be used for passengers using their own wheelchairs and should not be asked to stand up or transfer to wheelchairs provided by the airport. A wheelchair user unable to move, raise hands, etc. shall be subjected to secondary screening and shall undergo a pat down (frisk search) by a screening officer of the same gender. Screening officers shall obtain consent to conduct a frisk search. Before a frisk search is carried out, the screener shall offer the use of a private search room/enclosure which will be made available upon request.
- d. For passengers who are blind/low vision the screening staff shall:
  - i) offer screening options to stand or sit for primary screening;
  - ii) assist persons through the Walk-Through Metal Detector (WTMD);
  - iii) provide an option for private screening;
  - iv) where a physical search of personal belongings is required, replace all items where they were originally located;
  - v) make certain that an assistance animal, such as a guide dog, is not separated from a person during screening;
  - vi) shall make or put up identification mark on the baggage;
  - vii) identity card or badge No. of the "assistant" provided to escort the passengers who are blind/low vision must be communicated in writing.
- e. For passengers with Hearing Impairment, the following techniques can be used:
  - i) speak in a normal tone and pace, in a clear and concise manner;
  - ii) use hand signals and gestures to help express spoken direction (pointing and nodding);
  - iii) maintain eye contact at all times and speak directly to the person with the impairment;
  - iv) point out visual alarms by physical indication; and
  - v) if communication difficulties persist, screening officers shall use written instructions to communicate to the guest.
- f. For passengers with hidden disabilities the following techniques can be used:
  - i) If requested, allow escort to assist, and go through security check, with person with disability of opposite sex.

### **2.5.7 Post Security Check - Responsibility of the airport operator**

- i) While moving passengers to the waiting area after the security check, passengers may be assisted to visit the restroom if required.
- ii) Certain groups (not just anxiety prone, those with autism or psycho-social disability) should be given seats close to the restrooms, if requested. This allows easy movement and spaces near the restroom suffice as 'breathing corners'. Some passengers who get over stimulated or disorientated in large spaces, with many sounds, lights, brightness should be provided with a place in a corner or away from such distractions during boarding.
- iii) Certain groups of persons with disabilities require help in filling forms. Some might need 'comfort' during flight cancellations or delays, which can be provided by any airport staff who could sit with the person and make him/her feel less anxious or troubled. Their training should include 'identifying such needs' as not all people who are anxious are persons with disabilities and vice versa, though the practice can be made universal. Children below 12 who travel alone are often taken care by the cabin crew. Such care practice should include reminding them when it is time to board, asking them if they would want to use the restroom before boarding, if they have their documents in place, who would be waiting for them at arrival etc.
- iv) If passenger is travelling with escort, the escort should be allowed to provide the assistance including pushing the wheelchair.

### **2.5.8 Part A Transfer to aircraft - Responsibility of the airport operator**

- i) Boarding the aircraft should be with the provision of boarding ramps, ambulifts, aerobridge, boarding-aisle chair, wheelchairs or other assistance needed, as appropriate.
- ii) No passenger shall be manually lifted.
- iii) If passenger is travelling with escort, the escort should be allowed to provide the assistance including pushing the wheelchair.

#### **Part B Transfer to aircraft – Responsibility of Airline**

Only low floor buses with wheelchair accessibility shall be used by airlines. All airlines shall ensure that these are provided within a limited time frame and all buses that are not wheelchair accessibility shall either be retrofitted with the limited time frame or removed from service.

### **2.5.9 On Board - Responsibility of the Airline**

- i) Communication of essential information concerning a flight should be in accessible formats.
- ii) Communication of safety instructions should be in sign language/subtitling of safety video.
- iii) Provision of on-board entertainment should be in accessible formats.
- iv) Cabin crew should assist passenger to access toilet if requested using onboard aisle chair.
- v) Aisle chairs should be carried on board for flights longer than 3 hours.

### **2.5.10 Disembarking - Responsibility of the airport operator**

- i) Checked-in wheelchair may be collected and brought to the aircraft if passenger wishes to use own wheelchair as informed at departure airport.
- ii) The baggage stored in the aircraft will be retrieved.
- iii) Disembarking from the aircraft should be with the provision of ambulifts, aerobridge, wheelchairs or other assistance needed, as appropriate.
- iv) No passenger shall be manually lifted.
- v) If passenger is travelling with escort, the escort should be allowed to provide the assistance including pushing the wheelchair.
- vi) Assistance may be provided to proceed from the aircraft to the baggage hall and to retrieve baggage, with completion of immigration and customs procedures, and further to a designated point as requested by passenger, reaching connecting flights when in transit, and moving to the toilet facilities if required.

## **3. Accessibility of ticketing systems and websites not covered**

3.1 Persons with visual impairment, dyslexia, learning disabilities and other print disabilities are not able to purchase tickets or access other information relating to air travel because ticketing websites and websites of airlines and airports are not accessible. The CAR does not mandate that these websites must be accessible throughout.

3.2 **Suggestions:** The W3C web accessibility standards (available at <http://www.w3.org/WAI/intro/wcag.php>) should be implemented by all stakeholders offering information on the internet, including airlines and ticketing companies. There must be a tab on the main page of the airline website with the airline disability policy and guidance for disabled passengers. Airlines and ticketing agencies must ensure equal access to websites and ticketing for persons with disabilities, including by removing barriers that currently exist, such as, lack of accessible internet ticketing, special fares being hidden within graphics, time limits that preclude some persons with disabilities from booking reservations online, or offering discounted fares that are not available if a person with a disability makes a reservation by telephone.

#### **4. No complaints and redress mechanism**

- 4.1 The CAR does not prescribe complaints and redress mechanism in the event of breach of the CAR. Any breach of the CAR must result in a) penalty being imposed; and b) compensation being paid to the passenger. The CAR will be an ineffective regulation without a proper and effective complaints and redress mechanism.
- 4.2 As per the existing CAR, the Aircraft Act 1934 and the Aircraft Rules, the DGCA has no powers to address complaints from passengers, including passengers with disabilities. We understand from the Ministry of Civil Aviation that it proposes to set up an ombudsman to address the complaints from all passengers, including passengers with disabilities. A study of Sections 5 and 5A of the Aircraft Act, 1934 indicates that the Central Government has the necessary powers to set up an ombudsman without requiring an amendment to the Aircraft Act, 1934. This would mean that the ombudsman can be set up swiftly.
- 4.3 It is critical that the complaints mechanism to address complaints relating to the CAR must be impartial and have the necessary powers to effectively deal with complaints. The complaints mechanism must also be accessible for persons with all forms of disabilities and all forms of assistance must be provided to persons with disabilities who wish to file complaints. Some of the critical aspects to be covered in the complaints redress mechanism are the following:

##### **4.3.1 At Airports**

- i) Each airport must have at least one Complaints Resolution Officer (“**CRO**”), with larger airports requiring additional CROs. The CRO shall be independent and under the control of the ombudsman. Each CRO will be specifically trained and must be fully aware of the CAR and all disability related issues. At each airport, each airline shall designate a person in a senior position to interact with the CRO if required by the CRO. Such person designated by the airline will be specifically trained and must be fully aware of the CAR and all disability related issues
- ii) The CRO shall be available to any person who complains of alleged violations of the CAR at all times that the airport is operational. If the CRO is not available, the CRO must be penalized by fines which are dissuasive.
- iii) In the event any passenger faces any alleged violation of the CAR, the passenger may contact the CRO who will attempt to mediate between the passenger and the airport/airline so that issue is resolved.
- iv) In the event the issue is not successfully resolved in the opinion of the passenger, or if the CRO is contacted after the alleged violation has occurred, the passenger may choose to

lodge an official complaint with the CRO. The CRO will provide all assistance required by the passenger to lodge the complaint.

- v) If a complaint is lodged, the CRO shall record the complaint in the presence of the complainant and the airline/airport official that is responsible for the alleged violation and provide to the complainant and the airline/airport official a copy of the complaint and both parties shall sign off on the facts. This fact sheet will then be set to ombudsman by the CRO.
- vi) If either the complainant or the airline/airport official that is responsible for the alleged complaint does not agree with the summary of facts recorded by the CRO, the complainant shall be free to file a complaint with the CRO with his/her version of the facts. The CRO will also collect the version of the facts as presented by the airline/airport official that is responsible for the alleged complaint. The CRO will then forward the complaint along with the version of the facts of the airline/airport official to the ombudsman. If the airline/airport official refuses to give their version of the facts to CRO, the CRO shall make a note of this and forward this information to the ombudsman.

#### **4.3.2 Complaints over the Internet or by post/courier**

Passengers must also be given the option to lodge complaints over the Internet with the ombudsman or by post/courier. For this purpose, a fully accessible website must be created which specifies the information to be provided for the complaint, its format and other relevant details. The passengers should be able to lodge complaints via email or post based on the information provided on the website. The status of all complaints must be made available on the website and must be updated on a daily basis.

#### **4.3.3 Powers of the Ombudsman<sup>3</sup>**

The Ombudsman, when appointed, shall be fully empowered to:

- i) Call for information and conduct investigations in relation to complaints.
- ii) Settle complaints between the complainant and the airport/airline through conciliation and mediation if the parties mutually agree to settle the matter.
- iii) Impose penalties including fines. The penalties should be effective, proportionate and dissuasive. The current penalties are a maximum of Rs. 2 lakhs or 6 months imprisonment or both. The financial penalty must be substantially increased to the maximum permissible under the Act to ensure that it is dissuasive. Fines must be imposed on the concerned representative of the airline/airport and the airline/airport also. The principle to be applied when determining the quantum of penalties must be that the higher the authority of the person making the violation, the greater must be the penalty.

---

<sup>3</sup> The powers are loosely based on the powers of the Banking Ombudsman.

- iv) Award compensation subject to a maximum of Rs. 10 lakhs, as prescribed by the Government.

#### **4.4.4 Miscellaneous**

- i) Appeals from the order of the ombudsman will lie with the Government..
- ii) All complaints with the ombudsman must be disposed of within 3 months of the complaint being filed. A passenger must lodge a complaint within 1 month of travel.
- iii) All members of the ombudsman must be given comprehensive training on disability related issues.

#### **4.4.5 Interim measures**

Since the setting up of the ombudsman may not require amendments to the Aircraft Act/Rules the ombudsman must be set up as soon as possible, if possible, within the next six months.

### **5. AIRPORT FACILITIES & EQUIPMENT**

#### **5.1 Accessible routes and passageways**

- 5.1.1 Passenger walkways, including crossings to the terminal building, should be accessible to persons with disabilities.
- 5.1.2 Airport operators should have an accessible route of travel for boarding and disembarking aircraft.
- 5.1.3 All areas in the terminal building that are open to the travelling public should include facilities designed in such a way that persons with disabilities, can reach and use them without difficulty, in particular:
  - a) lavatories;
  - b) restaurants;
  - c) shops;
  - d) communication equipment; and
  - e) information and check-in counters
  - f) drop off and pick-up areas
  - g) exterior paths of travel such as parking areas
  - h) lounges
- 5.1.4 Airport operators should ensure that new barriers are not created on accessible routes. Accessible path of travel should be checked on a regular basis and any obstructions should be removed.
- 5.1.5 Systems of intra and inter-terminal transportation (e.g. moving sidewalks) should comply with national legislation on accessibility standards.
- 5.1.6 Fire alarms or emergency warnings/instructions that are provided in a form which is accessible to all.

5.1.7 All announcements at the airport should be made both visually and orally. In this way sensory impaired people are given equal access to the information provided to other passengers.

## 5.2 Wayfinding

5.2.1 Airport operators should incorporate wayfinding methods which minimize reliance on directional information.

5.2.2 Wayfinding methods include visual contrast, detectable (e.g. tactile) patterns on floors and walls to indicate direction, arrangement of architectural features such as walls or columns, etc.

5.2.3 Electronic indoor navigation system needs to be provided. These concepts have been developed and tested abroad. Using this system, a user with the appropriate devices can navigate to points of interest including toilets, restaurants etc.

## 5.3 Signage

5.3.1 Facilities that are reserved or designed for persons with disabilities should have signage in accordance with internationally-agreed standards. All other signs should take account of the needs of persons with disabilities.

5.3.2 Airport operators should ensure that when persons with disabilities arrive at the airport, signage is clear and enables them to find their way easily to the correct part of the airport.

5.3.3 Airport operators should ensure that signs used for washrooms, emergency exits, elevators, stairwells, doors or passageways off main corridors, designated seating areas, and for gate, or departure area numbers include tactile symbols. Signs should be at eye-level with letters, symbols or pictograms that are glare-free, in high contrasting colours and of universal font and size. Letters should be sans serif and numbers should be Arabic. Signs should be supplemented by Braille where possible. Illuminated signs should not use red text on a dark background.

## 5.4 Automated kiosk

5.4.1 Airport operators should ensure that automated kiosks are accessible and identified with the international symbol of access. Automated kiosks provide travel-related services such as: confirming check-in; verifying photo identification; allowing seat selection; and dispensing boarding passes, baggage tags, and parking tickets. If kiosks cannot be made accessible, then an equivalent level of service should be provided to those persons who are unable to use them independently.

## 5.5 Accessible telecommunication systems

5.5.1 Some or all flight information systems should be installed at eye level.

- 5.5.2 Airport operators should ensure [telecommunications systems for use by the general public] are also accessible to persons with disabilities (such as telephones and internet terminals).
- 5.5.3 Airport operators should ensure that there are accessible public telephones [both landside and airside, for example in arrival and departure areas, boarding gates, baggage claim areas] that allow a person who uses a wheelchair, is blind or visually impaired, has a speech impairment, or is Deaf or hard of hearing to use the machine independently. For example, people who are Deaf or hard of hearing use telephone typewriter devices (TTYs) or require that the equipment be compatible with hearing aids, have volume control for those who do not have a hearing aid, and some kind of visual indication that their requests for assistance have been received.
- 5.5.4 The accessible telecommunications systems should be clearly identified using the international symbol of access or the identification sign for TTYs.
- 5.6 Public announcements
- 5.6.1 Airport and aircraft operators should ensure that public announcements concerning stops, delays, schedule changes, gate changes, connections, and claiming of baggage are made visually and verbally to persons with disabilities who request such a service.
- 5.7 Arrival/departure monitors
- 5.7.1 Airport operators should install some monitors at eye level (1.5 metres above the floor +/- 25 mm) in each area where monitors are used. Where monitors are placed above eye level, they should be placed so that they can be easily seen by persons with disabilities, including those using a wheelchair. Information screens should be visible from reserved seating areas. Monitors should be positioned to avoid glare.
- 5.7.2 Information displayed on the monitors should be in plain language that is easy to read and should avoid the use of acronyms.
- 5.7.3 When monitors or other electronic signs are used, good colour contrast should be provided, such as a light colour on a dark background, which is preferred. Red lettering on a black background is not to be used. Scrolling, flashing or dot matrix text also create accessibility barriers for some users and should be avoided, where possible.
- 5.8 Seating areas
- 5.8.1 Airport operators should also provide specially designated seating along the circulation path at regular intervals, for example in long corridors or passages to boarding areas, where possible.
- 5.8.2 Airport operators should provide seating in passenger service areas where there may be long waiting lines or times, including at ticket sales counters, check-in counters, secured screening and customs areas, and baggage retrieval areas.

- 5.8.3 Designated seating should be provided for passengers with disabilities at boarding gates and departure areas within viewing distance of communication boards, and within hearing range of audio announcements as well. Such seating areas should be identified by the universal symbol of accessibility, and shelter should be provided where this seating is outdoors.
- 5.8.4 Aircraft and airport staff should provide regular updates to persons with disabilities seated in these areas on the status of their flights and enquire about their needs. This is particularly important for visually impaired passengers who cannot read customer information screens.
- 5.8.5 At waiting lounges where a disabled person will wait while in transit must provide lounge chairs with option on straightening and raising ones legs that are accessible to disabled people especially for disabled persons who are unable to stand.

## 5.9 Relieving areas for service animals

- 5.9.1 Airport operators should ensure that there is an area available for service animals to relieve themselves, whether designated or not. Airports should ensure that staff and volunteers are made aware of the relieving areas so they know how to facilitate passage for travellers from secure areas to a relieving area and re-entry to make connections. There should be a safe path of travel between the terminal and suitable relieving areas.

- 5.9.2 Where possible, persons travelling with service animals should have access to a relieving area within secured areas for use between connections. If this is not possible, one should be easily accessed from secured areas to minimize the time required to relieve a service animal.

Note: Service animals may have different preferences for surfaces for relieving themselves. Generally, gravel or grass works well in a relieving area as not all animals will relieve themselves on hard surfaces such as concrete. Ideally, relieving areas should provide more than one surface.

- 5.9.3 Other considerations for relieving areas include providing a fenced in area, located away from high traffic areas, providing a garbage can or other container for the hygienic disposal of waste, and providing a water source to facilitate the cleaning of the area by staff. In addition, terminal operators may wish to consider providing plastic bags for cleanup. Signage should be provided which reminds users to clean up after their animals.

## 6. Review of the CAR

### 6.1 No assistance mandated for passengers with disabilities without mobility issues

The CAR does not mandate the provision of assistance to non-mobility impaired passengers. As a result, persons with mental, intellectual or sensory impairment but without mobility issues are not provided adequate assistance.

**Suggestions:** The CAR must provide for necessary assistance to be provided for persons with all types of disabilities at the earliest request. The nature of assistance required for each type of disability must be studied and added to the CAR. For instance, live assistance and intermediaries, including guides, readers and professional sign language interpreters must be provided as prescribed under Article 9 (2) (e) of the United Nations Convention on the Rights of Persons with Disabilities. Due to dual sensory loss, Communication and Accessibility is a major issue for deafblind persons. Deafblind persons face difficulties in accessing the physical environment and access to information is a major constraint. Tactile Sign language interpretation, Braille and large print signage and sighted guide service are very basic and unique needs of a deafblind person which need to be addressed. Persons with visual impairment must not be forced to use wheelchairs. Easy to read and understand forms must be provided. All information made available to passengers must be made available in Braille, large print and other accessible formats and easy to access formats such as pointer sheets for persons with cerebral palsy, pictobrilie, tactile and embossed signage for deafblind and signage displayed in prominent places and in lifts. When a person with disability is being assisted, he/she must be given a phone number or an intercom number to be able to call the assistant to request for help to move to the restroom or if the passenger requires water or some other assistance. Braille safety instructions should be made available to blind passengers. Such instructions should include a tactile diagram indicating emergency exits. Meal menus must be read out to the passengers with visual impairment. These are recommended<sup>45</sup> by the International Civil Aviation Organisation (“ICAO”). The assistance provided must also be gender sensitive and age sensitive and cater to the requirements of women and children with disabilities. The interaction and the manner of providing assistance must follow the best practices specified in Annexure 1 of this report.

## **6.2 No standards for training and sensitization prescribed**

While the CAR does prescribe that training and sensitization programs must be provided by airlines and airports, no standards are prescribed for such training and sensitization programs. The specific aspects of the training and sensitization programs which are to be covered are not prescribed. Moreover, often trainee cabin crew are inducted without any adequate training. As a result the training which is provided is wholly inadequate as is evident from the many instances of violation of the rights of air travelers with disability.

---

<sup>4</sup> Contracting States should take the necessary steps with airlines, airports, ground handling operators and travel agencies to ensure that persons with disabilities are given the information they need, and should take the necessary steps to ensure that airlines, air ports, ground handling operators and travel agencies are in a position to give those passengers the assistance necessary for them, depending on their needs, to help them in their travel – 8.22, Annex 9 - Facilitation to the Convention on International Civil Aviation

<sup>5</sup> Measures should be taken to ensure that the hearing- and vision impaired are able to obtain flight information. - 8.29, Annex 9 - Facilitation to the Convention on International Civil Aviation

The United States<sup>6</sup> and the European Union<sup>7</sup> have prescribed detailed instruction on interaction with travelers with disabilities, how to provide assistance etc.

**Suggestions:** Senior management and operations of relevant stakeholders, ground staff of airlines, airport staff, any private companies providing assistance at airports, as well as cabin crew, should all be trained to increase their general awareness on respecting the rights and dignity of persons with disabilities. In addition, those providing the actual assistance at all points of a person's journey need to have the requisite training, e.g., knowing what kind of assistance might be needed (or not) for persons with different impairments, how properly to give assistance including that involving handling of the physical person when relevant, as well as proper treatment of assistive devices. Training must ensure an adequate number of well trained persons for all parts of the passenger's journey, and must occur frequently enough to address the turnover of personnel.

Detailed training programs and training manuals must be evolved and prescribed based on the parameters specified in Annexure 2.

### 6.3 Accessibility of airports not covered

The CAR does not mandate that airports and airport infrastructure must be accessible nor does it adopt standards relating to accessibility or design of airports to meet the requirements of persons with disabilities. Unless buildings are accessible persons with disabilities will not be able to access airports and airport infrastructure.

#### Accessible Airport Infrastructure

Universal Design enables passengers with disabilities and with reduced mobility to move about safely, freely and use all facilities within the airport terminals. It also facilitates independent functioning of individuals, so that they can get into and participate in all activities of travel with dignity and safety.

Scope: These Standards on Universal Access to Airport terminal are applicable to all information, facilities and services used by travelling public. The Ministry of Urban Development (MoUD) has prepared Model Building Bye-laws, which contain provisions for improving access to various public building by disabled and elderly persons. The access standards given here are extracted from Model Building Bye-Laws, 2011 and National Building Code, 2005. Along with Bye-laws, CPWD "Space Standards for

---

<sup>6</sup> Air Travelers With Disabilities: Technical Assistance Manual for Airline Employees, Contractors, and Travelers', a publication by the Aviation Consumer Protection and Enforcement, US Dept of Transportation. Accessible at < <http://airconsumer.dot.gov/pubs.htm>> (Last accessed on 14<sup>th</sup> March 2012)

<sup>7</sup> ECAC policy statement in the field of civil aviation facilitation' (Document 30), a publication by the European Civil Aviation Conference. Accessible at < [https://www.ecac-ceac.org/publications\\_events\\_news/ecac\\_documents/ecac\\_docs](https://www.ecac-ceac.org/publications_events_news/ecac_documents/ecac_docs)>

Barrier Free Built Environment for Disabled and Elderly Persons” under revision by MoUD, international best practices/standards are also referred to, while making these guidelines.

Areas Covered: All areas and services in the terminal building that are open to the travelling public should be accessible to persons with disabilities for example, toilets, smoking areas, restaurants and shops, business centres, executive lounges, leisure facilities, viewing galleries and places for prayer, etc.

The elements which are covered in these guidelines are:

Parking areas;	Exterior paths of travel;
Drop off and pick-up areas;	Wayfinding;
Signage;	Automated kiosk;
Public dealing counters;	Audio-visual displays;
Public telephones;	Rest aereas/seating;
Tactile paving – guiding & warning blocks;	Doors;
Steps and stairs;	Handrails;
Ramps;	Lifts;
Washrooms;	Drinking water units.

Detailed guidance material on the above points is given in the Guidance material on Accessible Airports Infrastructure (AAI) annexed with this report as Annexure 3.

#### **6.4 Standard operating procedures (SOPs) are not prescribed**

No standard operating procedures are prescribed under the CAR for handling persons with disabilities. As a consequence the services provided are ad-hoc and there is confusion as to handling particularly at the lower level.

**Suggestions:** The DGCA must detail specific standard operating procedures for handling of persons with disabilities in consultation with concerned stakeholders. Current BCAS guidelines may be updated to reflect a more wholistic approach towards disability / impairment. Code of conduct incorporating best practices for those providing support on ground and in the flight must be carefully developed and integrated into the SOP. This is very important as it will serve as a blueprint. As senior officers are not available at times this would be helpful for the junior personnel. This standard operating procedure must incorporate decision making tree in each aspect.

### **6.5 Lack of sufficient oversight of authorities to ensure that airports and airlines comply with regulations**

The CAR does not provide for any oversight by the DGCA to ensure that the airports and airlines comply with the regulations. Nor do the airports or the airlines have to report to the DGCA on compliance on a periodic basis. As a consequence airlines and airports are seen to be not complying with the CAR.

**Suggestions:** The CAR must be amended so that airlines and airports are mandated to keep the DGCA updated of compliance with the CAR. Airports and airlines must file periodic reports with the DGCA on the steps they have taken on complying with the CAR including but not limited to the training programs conducted, the details of the personnel to whom training was provided, the steps taken on accessibility and assistance etc. The DGCA must also make periodic checks of airports, airlines and intermediary parties like CISF, ground service agencies and aviation professional training institutes to ensure that they are adhering to the CAR. The details must be transparent and the DGCA must make available all the details of compliance and non-compliance on its website, which naturally should be GIGW & WCAG-2 compliant. In addition, the DGCA must conduct surprise checks at airports and of airlines to determine compliance.

### **6.6 Lack of clarity on when a person requires medical clearance and can be refused travel or requires medical certificates.**

As per Section 5.2 of the CAR medical clearance by the airline may be required when the airline has received information that the passenger who, (b) *because of certain diseases, or incapacitation* may have or develop an adverse physical condition which could have an adverse effect during flight and on safety and emergency evacuation procedures; (c) *would require medical attention and / or special equipment to maintain their health during the flights;* d) there exists a possibility of medical condition aggravated during or because of the flight. In addition the CAR specifies that “Persons with **specific disabilities** should plan to have all required forms for assistance ready in advance, to avoid flight delays.

It must be clarified what the specific conditions are without resorting to generic / catch-all descriptions. The terminology used is too vague and imprecise leading to misinterpretation, as was the case with Jeeja Ghosh, Anjlee Agarwal, Mohammed Asif and countless others. It is often seen on the ground that persons with disabilities are often considered by airlines/airports to have a medical conditions/medical patients, which is simply not the case.

**Suggestions:**The CAR should be reworded such that there is sufficient clarity on the exact grounds on which medical clearance is required by passengers and the medical grounds on which a passenger can be refused travel or offloaded. These must be

prescribed in the CAR as a specific list of conditions after taking due input from qualified medical and rehabilitation professionals. No person shall be refused travel or deplaned unless the medical officer in the airport and the CRO (as defined in section 4.3.1 of this report) agree that the person is not fit to travel.

It is difficult for the lay person to distinguish a person with illness from a person with disability in some cases. In other cases there may be an overlap. Even a medical professional will not be able to accurately assess a person's capacity by an on-spot medical assessment. The current process of identification of being fit-to-fly is unscientific and potentially discriminatory with purely visual 'screening' methods deployed. Actual incidents of in-flight fatalities or expenses incurred (by medical emergency disruptions / diversions) have proved little or no connection with disability - even behavioural issues are more due to anxiety/phobia of flying rather than pre-existing psychosocial issues.

Flight attendant reluctance/refusal undertake any additional out-of-the-way work that they assume may come their way with such passengers will be construed as bias as global standards commit that only passengers incapable of consuming accessible food/beverages by themselves or of self-toileting must be accompanied by an attendant. All other forms of support, including stowage of luggage, must be provided by aviation staff.

Given the above, it is therefore recommended that the practice of booking time declaration of illness / disability special assistance be adopted; by means of using IATA recommended forms MEDIF (Medical Information) , INCAD (Incapacitated Passengers Handling Advice) and FREMEC (Frequent Traveler Medical Card). While the MEDIF and INCAD forms only last for one journey, people who have stable, long-term disabilities and medical conditions may be urged to apply for a FREMEC card. The FREMEC gives the airline a permanent record of passenger-specific needs. This means the passenger will not have to fill in a form and make special arrangements for each flight as FREMEC cards are usually honored by other IATA airlines.

The CAR must incorporate cross-airline honoring of FREMEC cards and mandatory processes regarding issuing the same (Only Air India has reference to this, Jet and others only refer to the MEDIF) that would ease a lot of problems disabled passengers face. This needs to become part of the API (Advanced Passenger Information) process with machine readable format compliance. This would limit the use of airline / airport medical clearance to advance extraordinary events / emergencies. Guidelines for doctors on best practices in filling MEDIF forms and for airlines on MEDIF submission procedures would be advisable.

It must be emphasized that deciding fitness to fly or risk-assumption profiling on the basis of a person's appearance, disability category, perceived impairment, innocuous behavior perceived as suspicious or 'difference' is ground for anti-discrimination action.

Aviation staff may not “give in to” other passenger’s biases / preferences or ‘comfort levels’ with a co-passenger’s presence. Persons with disabilities must have access to all services, goods and information provided to other passengers as part of normal airport / airline operating practice. Treating passengers with disabilities any differently than other passengers except in making the necessary accommodations must be forbidden.

#### **6.7 No guidelines on standards of equipment at airports and on aircraft**

The CAR does not prescribe any standards for the equipment to be provided at airports and on aircraft. As a result the equipment provided is substandard, inappropriate, inadequate and often dangerous for use for persons with disabilities. Moreover, there is no readily available data with respect to how many wheelchairs/assistive devices are required for each airport.

**Suggestions:** It is essential that the equipment used at airports and on the aircraft is of high quality and is also maintained regularly. The wheelchairs that are provided must be of the types that have detachable armrests. There must be a choice between self propelled wheelchairs (large rear wheels) and wheelchairs that have all four small wheels. Aisle chairs must be provided to access the aisles in the aircraft. The aisle chair must have proper belts around the shoulder, waist and legs to hold a disabled person safely on it.

#### **6.8 No standards on accessibility of aircraft or equipment such as aisle chairs to be carried in aircraft**

The CAR does not mandate that aircraft themselves must be accessible. As a result, passengers with reduced mobility find it difficult, if not impossible to use the toilet on the aircraft and also access the seats in the aircraft.

**Suggestions:** As per the ICAO “Contracting States should introduce provisions by which aircraft coming newly into service or after major refurbishment should conform to minimum uniform standards of accessibility with respect to equipment on board aircraft which would include movable armrests, on-board wheelchairs, lavatories and suitable lighting and signs.”<sup>8</sup> This must be built into the CAR.

#### **6.9 No directions to CISF on security check and training**

At present there are no regulations covering the CISF on security check and training. There are regular violations by the CISF of the rights of persons with disabilities, humiliating treatment, asking people with calipers to remove their clothes etc.

**Suggestions:** Suggested training programme details for CISF personnel are proposed and are given in Annexure 4.

---

<sup>8</sup> 8.35, Annex 9 - Facilitation to the Convention on International Civil Aviation

### 6.10 Lack of clarity on seating versus safety

As per Section 7.2 (a) of the CAR “Incapacitated passengers and persons with disabilities or reduced mobility including blind shall not be restricted to any particular cabin or seating areas, except when it is done for *safety of passengers and avoid interference with evacuations* or due to physical limitations of the aircraft.” The CAR is unclear as to what constitutes safety of the passengers and what the meaning of avoidance of interference with evacuations is. As a result of this unclear wording, it is seen in practice that airlines regularly allocate seats to passengers with disability only near the toilets at the rear, and also refuse to seat two passengers with disability next to each other even if they are travelling together. This is a violation of the rights of persons with disabilities. It is particularly important for a deafblind person travelling with a sighted guide to have seats together. This is a very basic and unique need of a deafblind person, which should be mandatory for airlines to consider and provide for under any circumstance.

**Suggestions:** It is recognized that safety is paramount. However, it is unclear as to what seating arrangements would constitute lack of safety and interference with evacuations. This must be clarified, with specific reference to the exact seats that passengers with disability cannot be allotted for each type of aircraft. It must be also be explicitly clarified that persons with disabilities can be allotted seats next to each other provided that they are not seated in the seats identified as above. If a person with disability is travelling with a person without disability, they must be allotted seats together if available. Blind passengers as also others with disabilities, may be provided seats in the front with more leg space. This is not just a matter of passenger-comfort, but also convenience for the flight crew during meal service and other help and co-passengers sitting next. Providing aisle seat or window seat does not serve this purpose for persons with visual impairment, except in the front row. These passengers should be allowed such seats when they do tele check-in, which is denied at present on the ground that such seats are not controlled by the tele check-in people.

### 6.11 No clear directions on bar on indemnity forms

As per Section 5.1 of the CAR no special forms shall be insisted from persons with disabilities who only require special assistance at the airport for assistance in embarking/diseMBarking and a reasonable accommodation in flight, who otherwise do not require any additional assistance. However, there is no such bar on persons with medical conditions. As a result, airlines regularly treat persons with disabilities on par with persons with medical conditions and make persons with disabilities sign medical clearance/indemnity forms.

**Suggestions:** The CAR must clarify the situations under which medical clearance/indemnity forms must be signed by passengers with medical conditions. The default

system prescribed by the CAR must be that no medical clearance/indemnity forms are required unless and until the medical officer of the airline requires the passenger to sign the medical clearance/indemnity form. Inter-airline honoring of standard IATA forms MEDIF, INCAD & FREMEC must be set in place and this feature activated in booking / check-in /POC software systems like Galileo. Online submission of accessible versions of these forms must be incorporated in all ticket-booking websites.

#### **6.12 No mandate for curbside assistance kiosks**

As per Section 4.10 of the CAR the “airport operator shall display International symbol of Disability within the visible proximity of the main entrance of the arrival/departure terminal, informing that they may contact the concerned airline operator for special assistance.” However, in many cases it is not possible for the person with disability to reach the main entrance of the departure terminal from the place that he/she leaves the vehicle. This is the case with Terminal 3 in Delhi as well as in most other airports in the country. As a result it is virtually impossible for persons with disability to travel by themselves independently.

**Suggestions:** It is critical that curbside assistance kiosks are set up so that persons with disabilities do not have to walk to seek assistance. This type of assistance kiosk is currently operating at Terminal 1 at the end of path where cars are allowed. There must be adequate seating provided next to the assistance kiosk such that passengers with disability can wait while wheelchairs are brought. At the assistance kiosk the services specified in point e) above must be provided. It must also be recognized that some persons with disabilities arrive at the airport in autorickshaws and other similar modes of transportation. Since autorickshaws are not allowed into the airport in the same way that cars are, persons with disabilities may find it extremely difficult to arrive at the airport. Autorickshaws that carry persons with disabilities must therefore be allowed to approach the airport and the assistance kiosks. To avoid misuse of this facility, the passenger availing this facility should carry authenticated card to prove their status and those misusing this should be fined heavily. The CAR must also prescribe service levels for handling including the time within which services must be provided etc.

#### **6.13 No guidelines on availability of baggage tag for own wheelchair carried by the passenger to the boarding gate, assistive aids that can be carried on board and assistive aids that must be checked in, storage of assistive aids/equipment or consequences of damage to, or breakage of, assistive aids/equipment**

Under the present CAR, there are no guidelines on the availability of baggage tag for own wheelchair carried by the passenger to the boarding gate, assistive aids that can be carried on board and assistive aids that must be checked in storage of assistive

aids/equipment and how they are to be handled. Moreover there are no consequences prescribed for damage to, or breakage of, assistive aids/equipment.

**Suggestions:**The CAR must prescribe guidelines on provision of Limited Release Tag (LRT) or any other priority tag for own wheelchair carried by the passenger to the boarding gate and kept in hold; storage of assistive aids/equipment and follow international best practices. For instances, assistive aids/equipment that are checked in must be loaded on the aircraft last and off loaded first, assistive aids/equipment must not be sent on the conveyor belt etc. Additionally the CAR must prescribe strict penalty for damage to, or breakage of, assistive aids/equipment as well provide for compensation to the passenger. The CAR must also prescribe a list of assistive aids that can be carried on board and assistive aids that must be checked in. All assistive aids that the passengers requires on board during the flight such as AAC systems (Voice output device which may be battery operated / computer based), white canes, crutches etc. must be carried on board. A visually impaired passenger must be able to retain his white cane with him at all times.

#### **6.14 No procedure for requesting assistance in advance**

The CAR does not lay down the procedure by which passengers can request assistance in advance from airports over the telephone nor does it mandate that a telephonic help desk must be set up for assistance at the airports. This is essential since in many cases, passengers may not be able to request assistance over the internet. This may also be automated in the API (Advance Passenger Information) code when booking tickets, for frequent fliers with disabilities.

**Suggestions:** A centralized telephonic held desk facility must be set up to request assistance in advance. This (and other such customer telecommunication facilities) provided must be adaptable to use by the range of people who are hard of hearing/deaf and/or have visual impairment or speech difficulties to various extents. This help desk facility should then send the relevant information to the concerned airlines and the airports so that they are aware of the details of the passenger travelling and his/her requirements. The CAR must also mandate that each airport must have a telephonic help desk facility for passengers to contact the airport and request assistance in advance. The proper information pathway between the help desk, the airports and the airlines must be set up to facilitate this.

#### **6.15 No coverage of travel agencies**

The CAR does not cover travel agencies and the services/assistance that they are required to provide passengers with disabilities with respect to air travel. As a result, persons with disabilities cannot effectively access travel agencies or tour operators for their air travel requirements.

**Suggestions:** As per the ICAO<sup>9</sup> “Contracting States should take the necessary steps with airlines, airports, ground handling operators and *travel agencies* to ensure that persons with disabilities are given the information they need, and should take the necessary steps to ensure that airlines, airports, ground handling operators and travel agencies are in a position to give those passengers the assistance necessary for them, depending on their needs, to help them in their travel.” This must be adequately reflected in the CAR.

**6.16 No mandate for location of dedicated parking space at airports for persons with disabilities and no requirement for facilitation of movement from parking space to airport.**

As per Section 4.10 (a) of the CAR the airport operator shall provide dedicated reserved parking space. However, the locations where these parking spaces are to be provided are not specified. Moreover, there is no mandate that the movement of persons with disabilities from the parking space to the airport terminals/assistance kiosks must be facilitated. Consequently, passengers with disabilities who come to the airport independently in their own vehicles cannot access the airport.

**Suggestions:** As per the ICAO “Adequate parking facilities should be provided for people with mobility needs and appropriate measures taken to facilitate their movement between parking areas and the terminal buildings.” It is critical that the CAR must specify that parking for persons with disabilities must be provided as close to the accessibility kiosks as possible, and that their movement between parking areas and the airport terminal buildings/co-located transit points must be facilitated. This is where the importance of the telephonic help desk at the airport specified in point 18 above becomes critical. Once a passenger reaches the parking spot, he/she should be able to call the help desk and get assistance at the car. Adequate marking of parking must be provided and people who misuse the parking must be penalized.

**6.17 No mandate on in-flight entertainment being made accessible**

The CAR does not mandate that the in-flight entertainment is made accessible for persons who are hard of hearing or have visual impairment. As a result persons with these disabilities are discriminated against.

**Suggestions:** All movies/videos shown on aircraft should have subtitles for passengers who are hard of hearing and all movies/videos shown on aircraft must have audio descriptions for passengers with visual impairment. Passengers with visual impairment must be given assistance to access the entertainment systems through Braille display

---

<sup>9</sup> 8.25, Annex 9 - Facilitation to the Convention on International Civil Aviation

equipment accessible to the deafblind. Alternatively in-flight entertainment could include some Braille literature for reading during the flight.

**6.18 No mandate that safety briefings in aircraft must be made in sign language for persons who are hard of hearing/deaf. In addition there is no mandate that the use of oxygen masks and flotation jackets are to be demonstrated to blind passengers.**

The CAR does not mandate that the safety briefings about seat belts, oxygen, life vests etc. must be made in sign language for persons who are hard of hearing/deaf. In addition there is no mandate that the use of oxygen masks and flotation jackets are to be demonstrated to blind passengers. As a consequence it is a safety risk for passengers which can be easily avoided.

**Suggestions:** All safety briefings must be made in sign language so that persons who are hard of hearing/deaf can follow the safety briefings. If the safety briefings are shown on the screen, then subtitles must be given so that persons who are hard of hearing/deaf can follow the safety briefings. In addition the use of oxygen masks and flotation jackets must be demonstrated to blind passengers. For a deafblind person the briefing should be either in tactile sign language or they must be provided with instructions in Braille. The location of the nearest emergency exit and of the nearest toilet must be pointed out and physically shown as well as the position of the call bell.

**6.19 No mandate to provide replacement wheelchairs in the event of loss/damage for temporary use.**

The CAR does not mandate that replacement wheelchairs must be provided in the event of loss/damage to wheelchairs. It is seen in many instances that wheelchairs are damaged or lost in transit and passengers become immobile as a consequence on reaching their destination

**Suggestions:** The CAR must prescribe that temporary replacement wheelchairs must be provided to passengers on a like-for-like basis as far as possible, free of cost. This may be contracted from a profitable Rent-A-Wheelchair pan-India social venture.

**6.20 No guidelines relating to the maximum permissible weight and dimensions of assistive aids/equipment to carried**

At present the CAR does not prescribe the maximum permissible weight and dimensions of assistive aids/equipment that can be carried on board and checked in. Motorized wheelchairs can weigh anywhere in the range of 100 kilos and there are instances where there have been issues checking-in these wheelchairs.

**Suggestions:** The CAR may examine to prescribe that irrespective of the weight and dimensions of assistive aids/equipment they can be checked in free of cost . It is

important that the permissible weight is high enough such that motorized wheel chairs and mobility scooters can be checked-in free of cost. All assistive aids/equipment that can fit in the internal storage space shall be allowed to be taken on board. Other than for takeoff and landing, the assistive aids shall be made available for the passenger on request.

#### **6.21 No priority in using toilet facilities in aircraft**

At present the CAR does not prescribe that persons with disabilities should have priority to access the toilets in aircrafts.

**Suggestions:** The CAR must prescribe that persons with disabilities must be given priority to access toilets on the aircraft.

#### **6.22 No mandate for priority check-in counters**

At present the CAR does not prescribe priority check in counters for those people who may require a quick check-in (especially individuals with autism/learning difficulties who may not stay still and need to be checked in quickly)

**Suggestions:** The CAR must prescribe that airlines shall operate priority check-in counters for those persons with disabilities who require quick check-in.

#### **6.23 Further clarity required on guide dogs**

There is lack of clarity in the CAR with respect to treatment of guide dogs.

**Suggestions:** The CAR should examine whether Guide dogs accompanying passengers with disabilities be permitted to be carried (preferably free of charge) in the cabin. Persons travelling with guide dogs may be allowed to settle the dog at their feet and preferably should be seated at a bulkhead or where there is extra space, unless otherwise requested. The dog need not be muzzled. If the flight exceeds two hours in duration water only should be offered to the dog. There should be no petting of the guide dog by airline personnel.

\*\*\*

**Annexure 1**

**International Best Practices on Interaction with Person with Disabilities**

All disability related best practices are covered under all or any of the following three aspects: - Communication, Guiding the person, Service Animals

**1. Blind:**

a) Communication

- i) Enquire with the person with disability if he needs assistance giving him an opportunity to accept and receive assistance.
- ii) Begin communication with the person with disability by introducing oneself along with job responsibility. Always communicate using words. Communicate in words every action / gesture.
- iii) Keep the person with disability informed of all passenger related information as and when it becomes available. All visual displays must be communicated orally. It must not be presumed that the person with disability has knowledge of all passenger related information.
- iv) Individual safety briefings if required must be conducted discreetly with respect for the privacy of the persons with disability.
- v) Screening the baggage of the persons with disabilities must be done in the presence of a witness. Contents must be packed and replaced exactly where they were found.
- vi) Confidentiality of medical and other personal information must be maintained.
- vii) Enquire the person with disability for their specific needs especially in cases where the term used by the person with disability to describe his disability is not understood. Additionally, contact the Complaints Resolution Official (CRO i.e. a person who is thoroughly familiar with law dealing with the best practices in air travel persons with disabilities and the policies and procedures of the air carrier relating to the law, services, facilities and accommodation to such passengers etc) for more details and how to provide assistance to the person with disability.

b) Guiding the person

- i) Enquire if they need assistance in being guided through the airport. Offer them a hand and give them an option to take it.
- ii) While guiding, inform them of the various facilities available in the airport and allow them to choose what facility is to be used.
- iii) Warnings of any obstacle in their path must be as specific as possible. For example, whether they are going to use stairways or escalators, how the doors open or whether they would be using revolving doors.
- iv) Inform the persons of their location to familiarize them with the airport terminal.
- v) Once the person has been guided to his destination, seek to know if he needs any further assistance and allow him to opt for any requirement in assistance from other

passengers or air carrier personnel. If such additional assistance is required, other passengers or air carrier personnel must be informed of the PWD's need for additional assistance.

c) **Service Animals and Assistive Devices**

- i) Service animals must not be distracted or separated from the PWD
- ii) Assistive devices such as cane placed near the foot of the PWD's seat must not be moved. Permission of the PWD must be sought before moving or collecting the PWD's things.

**2. Deaf, Deafblind, Hard of hearing**

a) **Communication**

- i) Person responsible for providing assistance must introduce themselves and inform the PWD of their job responsibility.
- ii) Keep the person with disability informed of all passenger related information as and when it becomes available. All information must be provided in an accessible mode of communication.
- iii) Individual safety briefings if required must be conducted discreetly with respect for the privacy of the persons with disability.
- iv) Seek to know if the person with disability would like to communicate in writing.
- v) While communicating, the person assisting the PWD who is deaf or hard of hearing must look directly in the eye and use normal tone and lip movement. Rephrase the message being communicated in cases where the lip movement for certain words is similar.
- vi) Enquire the person with disability for their specific needs especially in cases where the term used by the person with disability to describe his disability is not understood. Additionally, contact the Complaints Resolution Official (CRO i.e. a person who is thoroughly familiar with law dealing with the best practices in air travel persons with disabilities and the policies and procedures of the air carrier relating to the law, services, facilities and accommodation to such passengers etc) for more details and how to provide assistance to the person with disability.
- vii) Must be remembered that persons who are deaf, hard of hearing, or deaf-blind have various ways of communicating, e.g., sign language, speech/lip reading, text telephone, hearing aid, implant or palm-printing method. Deafness can go unnoticed unless the PWD identifies himself as a person who is deaf, hard of hearing, or deaf-blind.
- viii) Persons who provide assistance must be aware of reading and interpreting the Braille text. Some persons with disabilities especially the deaf-blind might prefer to communicate using Braille card, in which they will require the persons assisting them to point out the Braille version of letters being communicated.

- b) Guiding the person:
  - i) Enquire if they need assistance in being guided through the airport. Offer them a hand and give them an option to take it.
  - ii) If the PWD has a guide dog on one side, offer support on the other side.
  - iii) Since persons who are deafblind cannot hear obstacle warnings, such information must be given tactually.
  - iv) Persons who are deafblind should not be left in an open space. Their hands must be placed on a wall, post or railing for support.
  
- c) Service Animals  
Service animals must not be distracted or separated from the PWD

### **3. Persons who have mobility disability**

- a) Communication
  - i) Speak to PWD by looking directly in the eye. Must sit nearby or stoop down to be closer to eye level, if the person is using a wheelchair
  - ii) Individual safety briefings if required must be conducted discreetly with respect for the privacy of the persons with disability.
  - iii) Enquire the person with disability for their specific needs especially in cases where the term used by the person with disability to describe his disability is not understood. Additionally, contact the Complaints Resolution Official (CRO i.e. a person who is thoroughly familiar with law dealing with the best practices in air travel persons with disabilities and the policies and procedures of the air carrier relating to the law, services, facilities and accommodation to such passengers etc) for more details and how to provide assistance to the person with disability.
  - iv) Best practices while assisting wheelchair users:
    - a) Must ask permission of the wheelchair users before they are pushed
    - b) They must be offered help with opening heavy doors, picking up things fallen on the floor
    - c) The wheelchair must not be positioned such that the user faces a wall or some other obstacle.
    - d) If the terminals, check-in counters etc are not designed for wheelchair users, persons behind those counters must come to the side of their desk or terminal that's closest to that of the wheelchair user.
  
  - v) Best practices while assisting people with walking difficulties:

- a) Wherever possible, seats must be offered.
- b) Must be remembered that people with walking disabilities who use aids such as crutches, walking sticks etc will find it difficult to use their hand while standing.
- c) If lifts or elevators are available for use instead of stairs or escalators for a destination, the people with walking disabilities must be informed.
- d) Assistive Devices and providing assistance:
  - i) Persons who provide assistance must have knowledge of different kinds of wheelchairs provided or accommodated by the air carrier. They must also understand the proper functions and storage of the different wheelchairs and ask the PWDs for the best way to handle their devices.
  - ii) Persons who provide assistance must also have knowledge of the businesses which repair wheelchairs in case such information is sought by the PWDs.
  - iii) Seek to know the preferences and instructions of the PWDs if they are to be transferred from a wheelchair to a seat.
  - iv) PWDs shall never be hand-carried, even if they consent to being hand-carried. Hand-carrying shall be allowed only during emergency evacuation.
  - v) Provide the PWDs with an option to be pushed through the gates, terminals etc.
  - vi) Air carriers shall not charge the PWD for providing services or devices to them.
- b) Service Animals  
Service animals must not be distracted or separated from the PWD.

#### **4. Persons who have difficulty speaking**

- a) Communication
  - i) Seek the PWDs' preference on the method of communication
  - ii) Speak to the PWDs in a normal tone. Must listen patiently and allow them to complete their sentence and ask them to repeat their response if it has not been understood.
  - iii) Preferably, pose PWDs with questions that require short answers.
  - iv) Patience is the key and the persons who provide assistance must not complete the sentences of the persons who have difficulty speaking. They might speak slowly and must be given time to complete their sentences.

#### **5. Persons who have disabilities that are not apparent (invisible disabilities)**

- a) Communication

- i) Enquire if the person with disability needs assistance (it must not be imposed) and seek to know their specific needs. If there is a concern that the person is not medically stable enough to travel by air, a discreet enquiry should be made. The CRO may be involved if necessary.
  - ii) Individual safety briefings if required must be conducted discreetly with respect for the privacy of the persons with disability.
  - iii) in cases where the term used by the person with disability to describe his disability is not understood. Additionally, contact the Complaints Resolution Official (CRO i.e. a person who is thoroughly familiar with law dealing with the best practices in air travel persons with disabilities and the policies and procedures of the air carrier relating to the law, services, facilities and accommodation to such passengers etc) for more details and how to provide assistance to the person with disability.
  - iv) Persons who provide assistance must portray a calm and reassuring behaviour which makes the person with disability feel safe.
- b) Service Animals  
Service animals must not be distracted or separated from the PWD.

## **6. Persons having learning disabilities**

- a) Communication
  - i) Must not be assumed that the persons with disabilities might have knowledge of such information
  - ii) Short, simple language must be used for communication.
  - iii) Giving too much information at once must be avoided and a sentence must convey only one idea. Also giving of information must be limited to give only important information. Person with disability must be given time to answer.
  - iv) Instructions which need to be followed by the person with disability must be given in the order in which they must be followed.
  - v) Lack of feedback (oral or visual) must not be construed as inattentiveness. Instead the person providing assistance must try to find out if the person with disability has understood what was communicated.
  - vi) Notices, visual displays etc which contain important information must be provided in easy-to-read format. Wherever needed, such notices and visual displays must be explained to the person with disability
  - vii) If the person with learning disability speaks a language that the person providing assistance is not familiar with, help must be sought from a person who speaks the language.

\*\*\*

## **Training**

Training of staff is vital for providing quality service in a respectful manner to persons with disabilities. It is essential for staff to know their responsibilities and be able to perform them. Training for all staff in the chain of air travel/service delivery is needed to ensure the needs of persons with disabilities are appropriately met. Training should address the attitudinal, environmental/physical and organisational barriers that affect persons with disabilities in air transportation. Training should prepare staff to provide assistance to persons with disabilities as a professional service to which the person is entitled, rather than a favour or compassionate gesture.

### **Who should be trained?**

Training should be provided to all personnel who deal with the travelling public

Examples of personnel who deal with the travelling public:

- check-in and gate agents
- information desk agents
- lost and found desk agents
- parking agents
- agents who provide services implemented at the airport by State entities, or entities acting on their behalf, including:
  - border control and immigration
  - security
  - customs
  - police
- Services provided at the airport by other entities, including:
  - retailers
  - catering companies (restaurants, bars, lounges)
- Services provided off the airport premises by air carriers, travel agents and tour operators, including information and reservation services.
- Training should be provided to all staff who provide direct assistance to persons with disabilities, including personnel employed by contractors and subcontractors
- Examples of those who provide direct service:
  - Personnel providing services or physical assistance to persons with disabilities
  - Travel agents and booking agents

- Personnel from the Airport managing body, or any sub-contractor acting on its behalf, providing assistance to persons with disabilities at the airport, including
- assistance personnel
- airport management personnel making decisions about accessibility
- security staff
- complaints officers
- Personnel from the operating air carrier, including cabin crew

#### **Scope and content of training programs**

- a) Organizations that represent persons with disabilities should be consulted in the development and implementation of training programmes.
- b) Training should include an understanding of disability and its diversity including hidden disabilities such as autism, and help staff develops an awareness of and appropriate responses to persons with disabilities.
- c) Training should cover a diversity of disabilities, which includes:
  - physical, sensory, hidden or learning disabilities such as autism;
  - mental disabilities;
  - persons who use wheelchairs;
  - persons with walking difficulties or limitations in balance, agility or coordination that affect their mobility;
  - persons who are deaf or hard of hearing;
  - persons who are blind or partially sighted;
  - persons who are deaf/blind;
  - persons with impaired speech;
  - persons who are aged;
  - persons who require attendants and the role of the attendant; and
  - persons travelling with a service animal including the role and needs of that animal.
- d) Aircraft and airport operators should include in their operations manuals instructions indicating the special assistance to be provided, according to the type of disability.
- e) Employees and contractors should be trained about the policies and procedures of the aircraft or airport operator concerning persons with disabilities, and what legal obligations exist in national legislation and regulations.
- f) The content of the training should be appropriate to the duties of the person's job who is being trained.
- g) Training about how to seek and record the accommodation needs and information from persons with disabilities should be provided to booking agents.

- h) Training should be provided about communication: how to ask what assistance persons with disabilities need, and how best to provide it. For example, how to guide and orient a person who is blind.
- i) Employees and contractors should be trained how to recognize requests for communication accommodation from persons with hearing and/or visual impairments and how to respond – such as providing information in an appropriate format, as well as receiving information from persons with disabilities transmitted via their communication aids or devices.
- j) Employees and contractors should be trained how to communicate directly with persons with disabilities, who are in the best position to explain their needs, rather than a companion, assistant or interpreter.
- k) Employees and contractors should be trained to acknowledge and accept communication from escorts of those persons with disabilities who may have difficulty in communicating with strangers.
- l) Employees and contractors should be willing to accept specific needs of persons with disabilities that may be as simple as allowing the escort to accompany ward with disability through security check even when the ward is of the opposite gender and/or an adult.
- m) Airport staff to be trained to not prevent individuals with invisible disabilities, in particular adults, from being accompanied into the toilet meant for persons with disabilities, even if the escort is of the opposite gender.
- n) Employees and contractors who provide physical assistance should be trained to always ask the person what kind of assistance they need, and seek feedback to ensure they are providing appropriate assistance.
- o) In addition to general training, aircraft and airport operators should ensure that they properly train their employees and contractors who are required to handle different types of mobility aids. They should be required to be familiar with the procedures for securing, carrying and stowing mobility aids, including methods of dismantling, packaging, unpackaging and assembling these aids.
- p) Employees and contractors who provide physical assistance should be trained on how to assist persons with mobility aids through doors and on irregular and multi-level surfaces, steps, curbs and elevators.
- q) Training should be provided on transferring a person between their own mobility aid and a mobility aid provided by the aircraft or airport operator, and between that mobility aid and the passenger seat. Training should include instructions on lift techniques, asking the person with a disability about their preferred method of transfer, and performing the lifting with maximum consideration for the dignity, safety and comfort of the person with a disability and to avoid injury to the employee.

- r) Training should be provided on the proper and safe operation of equipment used to accommodate persons with disabilities, including enplaning and disembarkation assistance equipment and how to ensure the safety and dignity of passengers.
- s) Cabin crew training should be geared to familiarizing persons with disabilities with their immediate environment and possible hazards within the cabin, and assisting them in the competent use of the facilities that are provided.
- t) Training programmes and emergency procedures should include special provisions related to the evacuation of persons with disabilities.
- u) The screening officers at security check shall be trained and instructed in special screening methods for persons with disabilities or special needs for all the persons specified above.

**Initial training**

- a) Aircraft and airport operators should ensure employees and contractors complete initial training before their entry upon duty.
- b) Initial training should train personnel to an advanced, skilled and adept level that allows personnel to be able to accomplish their duties and provide the necessary services effectively and respectfully the first time.

**Refresher training**

- a) Aircraft and airport operators should provide refresher training periodically/when appropriate (annually or every 2 years, for example). Any feedback from passengers that signals necessary improvements should be incorporated into training programmes.
- b) Routine, ongoing training should be provided by way of information on new equipment, policies and procedures and the related implications on providing accommodation to meet the needs of persons with disabilities, as these are introduced or implemented.

\*\*\*

### **Annexure 3**

#### **Guidance Material on Accessible Airport Infrastructure**

Universal Design enables passengers with disabilities and with reduced mobility to move about safely, freely and use all facilities within the airport terminals. It also facilitates independent functioning of individuals, so that they can get into and participate in all activities of travel with dignity and safety.

#### **Scope**

These Standards on Universal Access to Airport terminal are applicable to all information, facilities and services used by travelling public. The Ministry of Urban Development (MoUD) has prepared Model Building Bye-laws, which contain provisions for improving access to various public buildings by disabled and elderly persons. The access standards given here are extracted from Model Building Bye-Laws, 2011 and National Building Code, 2005. Along with Bye-laws, CPWD "Space Standards for Barrier Free Built Environment for Disabled and Elderly Persons" under revision by MoUD, international best practices / standards are also referred to, while making these guidelines.

#### **Areas covered**

All areas and services in the terminal building that are open to the travelling public should be accessible to persons with disabilities for example, toilets, smoking areas, restaurants and shops, business centres, executive lounges, leisure facilities, viewing galleries and places for prayer, etc.

The elements which are covered in these guidelines are:

1. parking areas;
2. exterior paths of travel;
3. drop off and pick-up areas;
4. wayfinding;
5. signage;
6. automated kiosk;
7. public dealing counters;
8. audio-visual displays
9. public telephones;
10. rest areas /seating;
11. tactile paving- guiding & warning blocks;
12. doors;
13. steps and stairs;

14. handrails;
15. ramps;
16. lifts;
17. washrooms;
18. drinking water units.

### 1. Accessible parking<sup>10</sup>

- i. Accessible parking should be provided at both Arrival and Departure terminals.
- ii. Parking should be within 30 meters of the main entrance of the terminal building.
- iii. Two accessible parking lots with minimum width of 3600mm x 5000mm (figure 1) should be provided in at both Arrival and Departure terminals.
- iv. It should have the international signage painted on the ground and also on a signpost/board put near it at a height of 2 meter (figure 2). A notice board should also display that non-disabled persons who use these “parking facilities meant only for the disabled” would attract a penalty.
- v. The symbol should be large enough to be easily visible by person looking for the accessible parking, recommended size being 1000mm x 1000mm but not larger than 1500mm x 1500mm. With the preferred colours being white and blue, the sign painted on the floor should contrast in colour and luminosity with the floor colour.
- vi. There should be directional signs guiding people to the accessible parking.

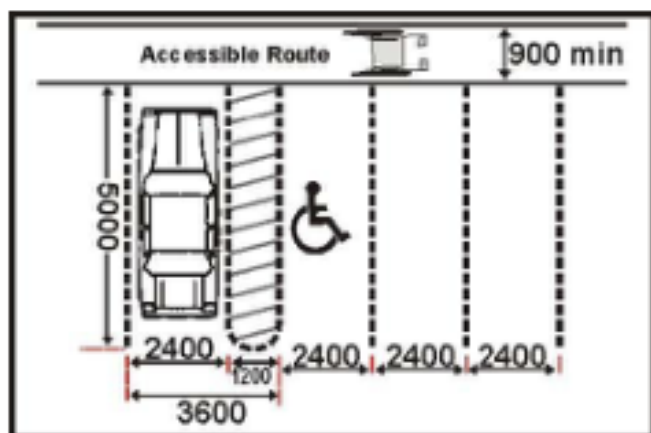

Figure 1 Accessible parking

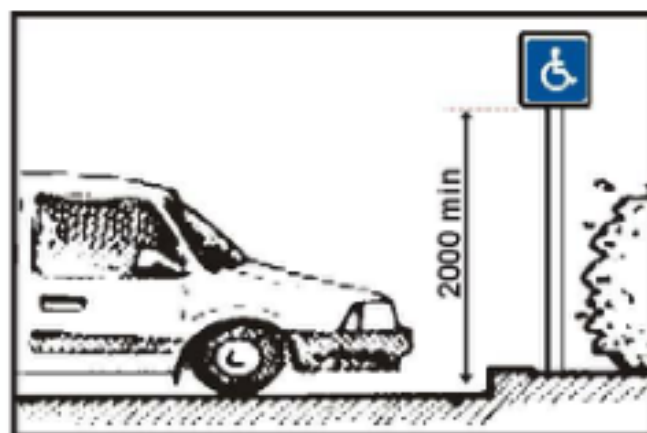

Figure 2 Signpost for accessible parking

### 2. Access Path/ Walkway

- i. Passenger walkways, including crossings to the terminal building, should be accessible to persons with disabilities. Airport operators should have an accessible route of travel for boarding and disembarking aircraft.

<sup>10</sup> Model Building Bye-laws, MoUD, 2012

- ii. Uneven surfaces should be repaired and anything that encroaches on corridors or paths of travel should be removed to avoid creating new barriers. Any obstructions or areas requiring maintenance should be cane detectable<sup>11</sup>.
- iii. Access path from plot entry and surface parking to terminal entrance shall have even surface without any steps.
- iv. Slope, if any, shall not have gradient greater than 5%. The walkway should not have a gradient exceeding 1:20. It also refers to cross slope.
- v. Texture change in walk ways adjacent to seating by means of tactile warning blocks should be provided for persons with vision impairment.
- vi. Avoid gratings in walks.

### Drop off and pick up areas<sup>12</sup>

- i. Designated drop-off and pick-up spaces, to be clearly marked with international symbol of accessibility (figure 7).
- ii. Kerbs wherever provided, should have kerb ramps.
  - Kerb should be dropped, to be flush with walk way, at a gradient no greater than 1:10 on both sides of necessary and convenient crossing points (figure 3). Width should not be less than 1200mm. If width (X) is less than 1200mm, then slope of the flared side shall not exceed 1:12.
  - Selection of floor tactile paving- Guiding & Warning blocks shall be provided (refer Section 11) to guide persons with vision impairment so that a person with vision impairment does not accidentally walk onto the road (figure 5).
  - Finishes shall have non slip surface with a texture traversable by a wheel chair.

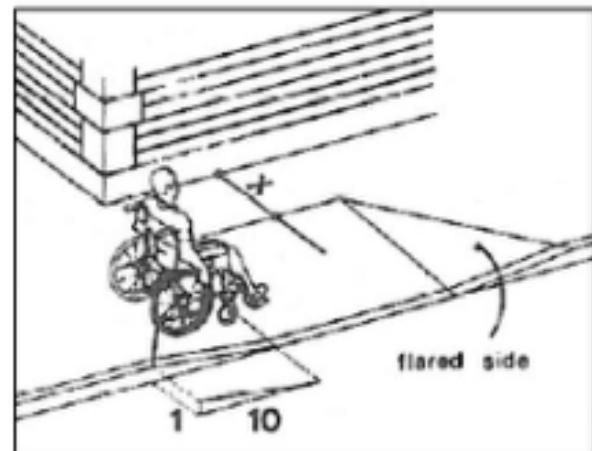

**Figure 3 Kerb ramp**

<sup>11</sup> <http://www.otc-cta.gc.ca/eng/publication/guide-passenger-terminal-accessibility/livre-book>

<sup>12</sup> Model Building Bye-laws, MoUD, 2012

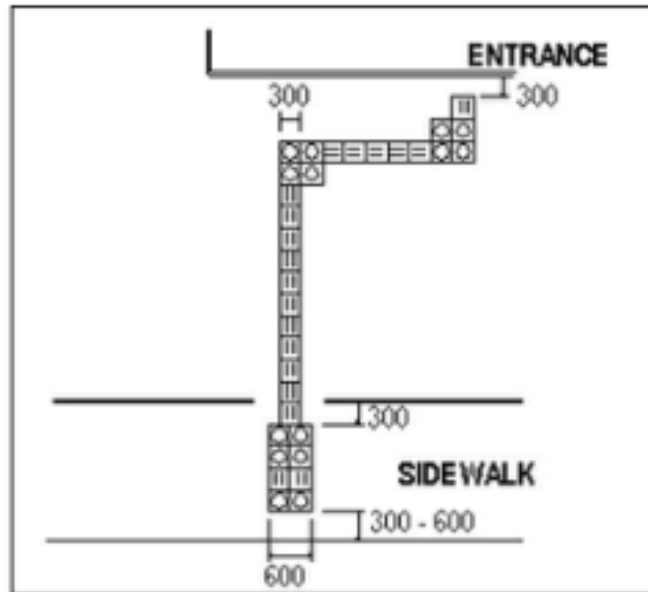

Figure 4 Tactile tile configuration for approach & entrance

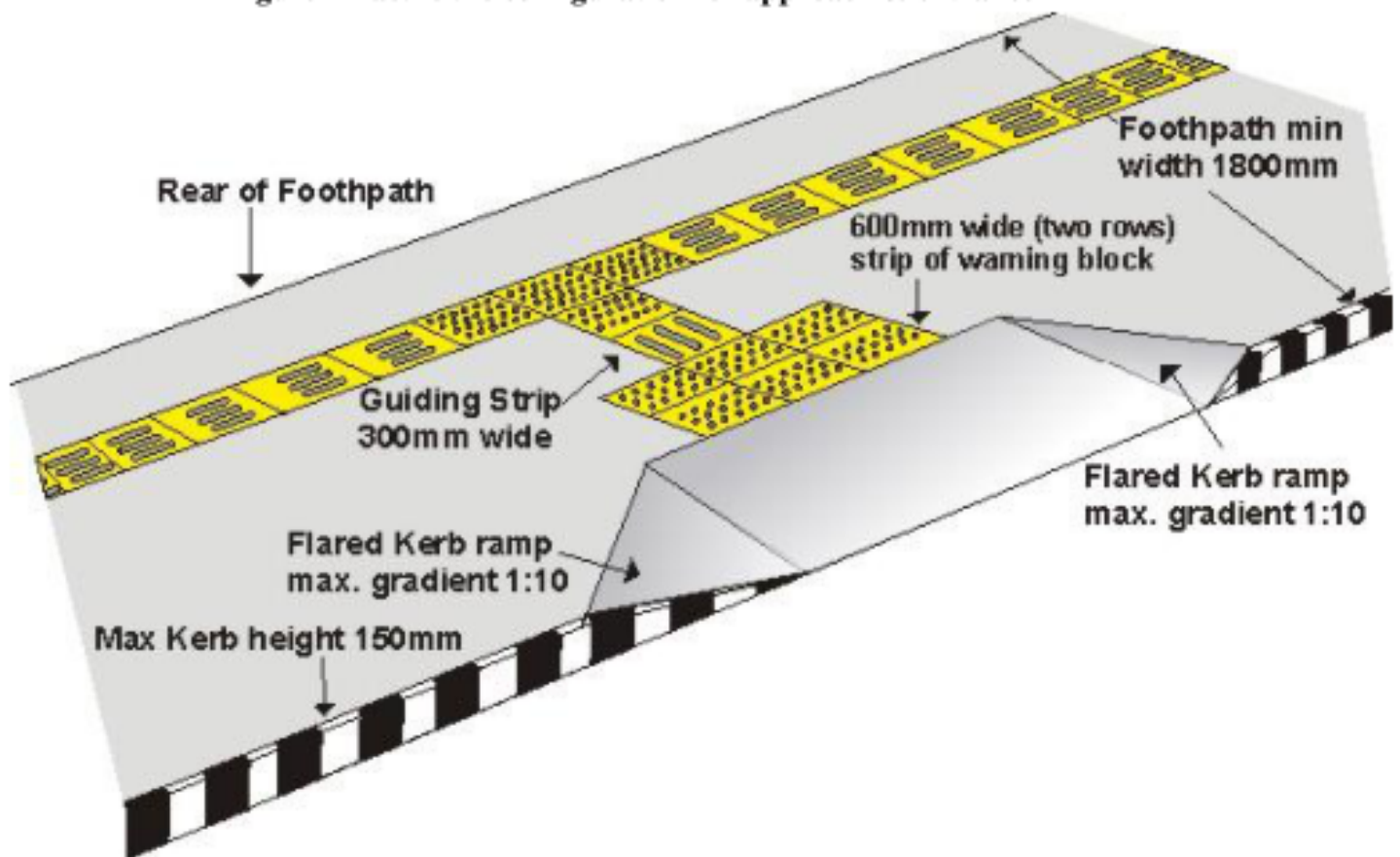

Figure 5 Kerb ramp<sup>13</sup>

<sup>13</sup> IRC 103:2012, Guidelines for Pedestrian Facilities, 2012

### 3. Wayfinding<sup>14</sup>

- Wayfinding references should be available at decision points.
- Colour can be used to identify routes and provide assistance in locating doors, walls and hazards. Proper colour contrast between different elements greatly improves visibility for all users and is critical for persons with low vision. For example, colour contrasting of door frames can assist in locating doors and floors should be contrasted with walls. In addition, furniture should contrast with walls and floors so as not to create an obstacle.
- Structural elements such as columns should be colour contrasted or brightly marked so as to be visible to those who may have a visual disability.
- Generally, patterns on flooring should be avoided or else should be minimal and small to avoid visual confusion.
- In addition to identifying hazards or warnings, tactile floor surfaces can also be used to inform that there is a change in area (e.g. leaving a corridor and entering a boarding area).
- Tactile systems should be consistent throughout the building. For example, terminals should not have carpeting in some boarding areas and tile in others as this may create confusion for those who rely on tactile surfaces to guide them to their destination.
- Good lighting assists those with a visual disability to see better and allows people who have a hearing impairment to lip read easier. However, care should be taken to properly direct lighting and to use matte finishes on floors, walls and signage, so as not to create glare which may create difficulties for all travellers.
- Blinds can be used to adjust lighting levels in areas where the natural lighting changes significantly throughout the day.

### 4. Signage<sup>15</sup>

Signs must be clear, concise, and consistent. All travelers need clear information about the purpose and layout of terminals to maintain a sense of direction and independent use of all facilities. Using internationally and nationally established symbols and pictograms with clear lettering and Braille ensures universal accessibility cutting across regional/cultural and language barriers. A cohesive information and signage system can provide visual (e.g. signs, notice boards), audible (e.g. public address and security systems, induction loops, telephones, and infrared devices), and/ or tactile information (e.g. signs with embossed lettering or Braille).

---

<sup>14</sup> <http://www.otc-cta.gc.ca/eng/publication/guide-passenger-terminal-accessibility/livre-book>

<sup>15</sup>

[http://www.urbanindia.nic.in/programme/ud/Research%20Study\\_Building%20Regulations\\_Access%20Standards.pdf](http://www.urbanindia.nic.in/programme/ud/Research%20Study_Building%20Regulations_Access%20Standards.pdf)

## 5.1 Sign Design Specifications

- The sign should be in a prominent position.
- The face of the sign should be well illuminated by natural or artificial light.
- Letters should be simple such as Arial, Helvetica medium, and san serif or similar and numbers should be Arabic.
- The colour of the text should be in a colour that contrasts with the sign board.
- The sign board should also contrast with the wall on which it is mounted.
- The surface of the sign should not be reflective.
- Some signs such as those adjacent to or on a toilet door may be embossed so that they can be read by touch.
- Illuminated signs should not use red text on a dark background.
- Signs should be supplemented by Braille where possible.



Figure 6. Way finding signage



Figure 7. International Symbol of Accessibility

### Automated kiosk

- Automated kiosks should be accessible for wheelchair users.
- Should be clearly marked with international symbol of accessibility.

## 6 Public Dealing Counters: Ticketing, Information, Check-in, Help desk, Restaurants, Shops, etc.

- Information or help desks should be close to the terminal entrance, and highly visible upon entering the terminal. In addition, they should be clearly identified and accessible to both those who use wheelchairs and those who stand.

- It should provide information in accessible formats, viz. Braille leaflets for persons with vision impairments.
- Ideally, these desks should have a map of the facility that desk attendants can view with passengers, when providing directions.
- Staff manning the counters should know sign language.
- Information desk acoustics should be carefully planned and controlled as a high level of background noise is confusing and disorienting to persons with hearing impairment.
- Lighting should be positioned to illuminate the receptionist/person manning the counter and the desk top without creating glare.
- Lighting should not create shadows over the receptionist staff, obscuring facial detail and making lip reading difficult.
- One of the counters should not be more than 800mm from the floor, with a minimum clear knee space of 650mm high and 280mm- 300mm deep (figure 8).
- If counter cannot be made accessible, then an equivalent level of service should be provided to those persons who are unable to use them independently.

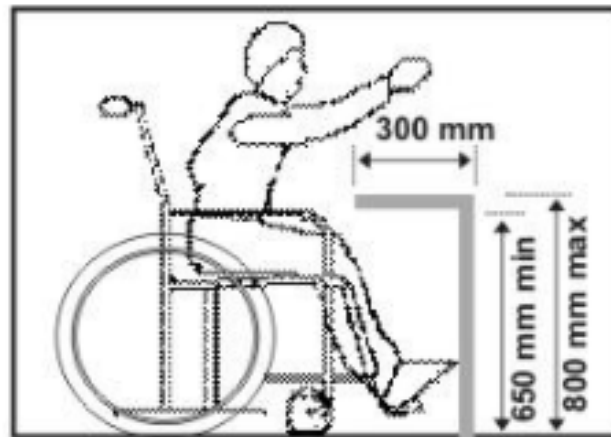

Figure 8

## 7 audio-visual displays<sup>16</sup>

- Terminal maps should be placed so that they are readily visible to persons who are standing and persons who use wheelchairs. Ideally, they should also be accessible to persons with a visual disability (i.e. tactile maps). Other alternatives include electronic navigation systems or audio maps.
- Enable captioning at all times on all televisions and other audiovisual displays that are capable of displaying captions and that are located in any portion of the terminal.

<sup>16</sup> <http://www.otc-cta.gc.ca/eng/publication/guide-passenger-terminal-accessibility/livre-book>

- The captioning must be high contrast for all information concerning flight safety, ticketing, flight check-in, flight delays or cancellations, schedule changes, boarding information, connections, gate assignments, checking baggage, individuals being paged by airlines, aircraft changes that affect the travel of persons with disabilities, and emergencies (e.g., fire, bomb threat).

## 8 Public Telephones

- All telephones should incorporate amplification, inductive couplers and facilities for blind and partially sighted people. At least one textphone facility compatible with the Typetalk relay service should be provided both landside and airside in each terminal for people who are deaf or hard of hearing. Those facilities should be indicated by clear signage.
- Public telephones should be made accessible to and usable by persons with disabilities so that it is convenient for use by wheelchairs users (photo 5).
- Maximum height of the highest part of a telephone: 1200mm (figure 9).
- Maximum height of a telephone (knee space for wheelchair user) 650mm-680mm.
- Minimum floor/ground space: 1200mm x 900mm (figure 10).
- Guiding path to be provided to guide persons with vision impairment to public telephones.

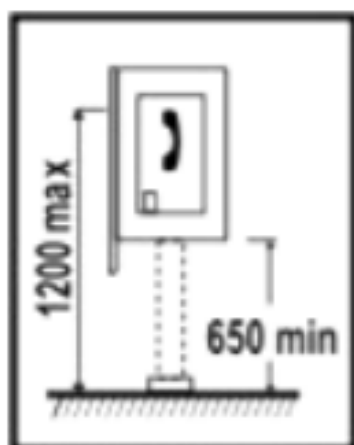

Figure 9

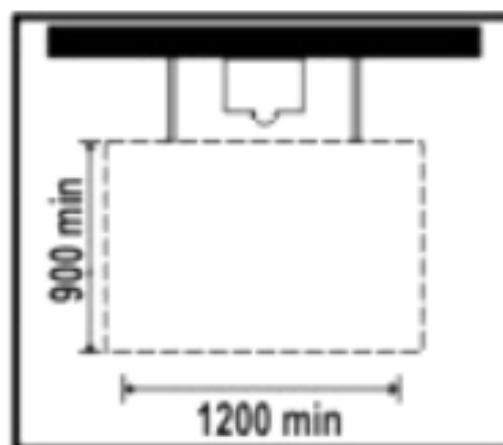

Figure 10

## 9 Rest areas /seating<sup>17</sup>

- Terminal operators should provide seating along the circulation path at regular intervals so that passengers do not need to walk more than 50 to 60 metres before being able to sit and rest.

---

<sup>17</sup> <http://www.otc-cta.gc.ca/eng/publication/guide-passenger-terminal-accessibility/livre-book>

- Where seating is provided, designated seating for passengers with disabilities is to be provided at boarding gates and departure areas within viewing distance of communication boards and/or personnel and identified by the universal symbol of access.
- Terminal operators should provide seating in passenger service areas where there may be long waiting lines or times, including at ticket sales counters, check-in counters, secured screening and customs areas, and baggage retrieval areas.
- Designated seating should be provided for passengers with disabilities at boarding gates and departure areas within viewing distance of communication boards, and within hearing range of audio announcements as well. Such seating areas should be identified by the universal symbol of accessibility, and shelter should be provided where this seating is outdoors.
- At waiting lounges for persons with disabilities will wait, while in transit, chairs should have armrests and backrest.

## 10 Tactile Paving- Guiding & Warning blocks<sup>18</sup>

**10.1 Tactile guiding blocks (Line-type)** indicate a barrier free route for a person with visual impairment (figure 11). It is recommended to install a row of tactile guidance tiles along the entire length of the proposed accessible route. Care must be taken to ensure that there are no obstacles, such as trees, poles or uneven surfaces, along the route traversed by the guidance blocks. Also, there should be clear headroom of at least 2.1 meters height above the tactile guidance blocks, free of protruding objects such as overhanging advertisement panel and signage, along the entire length of the walk.

**10.2 Tactile warning blocks (Dot-type)** indicate an approaching potential hazard or a change in direction of the walkway, and serve as a warning of the approaching danger to persons with visual impairments, preparing them to tread cautiously and expect obstacles along the travel path, traffic intersections, doorways, stairs, etc. (figure 12). The warning blocks prepare the person to tread cautiously. They are used to screen off obstacles, drop-offs or other hazards, to discourage movement in an incorrect direction, and to warn of a corner or junction. Two rows of tactile warning tiles should be installed across the entire width of the designated accessible passenger pathway at appropriate places such as before intersections, terminal entrances, obstacles such as signage, and each time the walkway changes direction.

### 10.3 Places to install warning blocks<sup>19</sup>

---

<sup>18</sup>

[http://www.urbanindia.nic.in/programme/ud/Research%20Study\\_Building%20Regulations\\_Access%20Standards.pdf](http://www.urbanindia.nic.in/programme/ud/Research%20Study_Building%20Regulations_Access%20Standards.pdf)

- In front of an area where traffic is present.
- In front of an entrance/exit to and from a staircase or multi-level crossing facility.
- Entrances/exits at airport terminals or boarding areas.

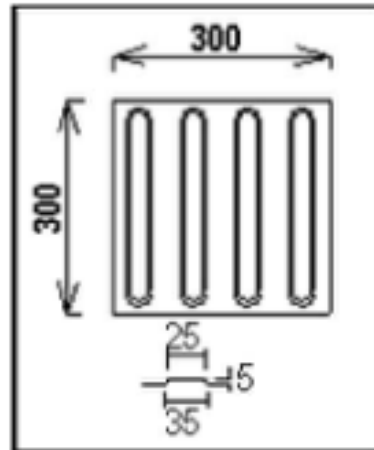

Figure 11 Guiding tiles

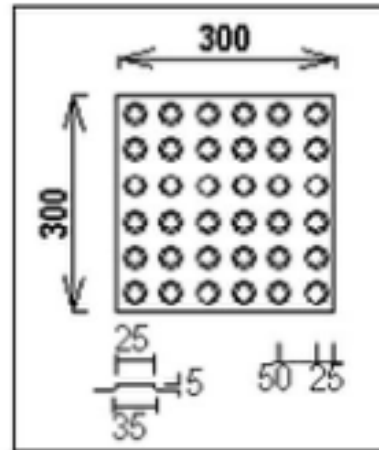

Figure 12 Warning tiles

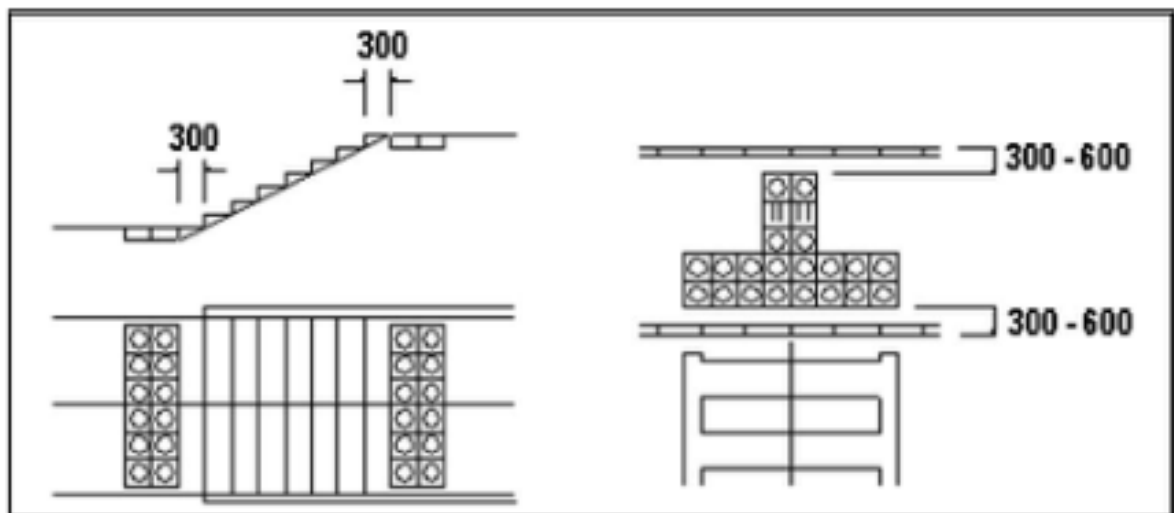

Figure 13 Placement of warning blocks for steps

<sup>19</sup> Space Standards for Barrier Free Built Environment for Disabled and Elderly Persons, CPWD guidelines , 1998, MoUD

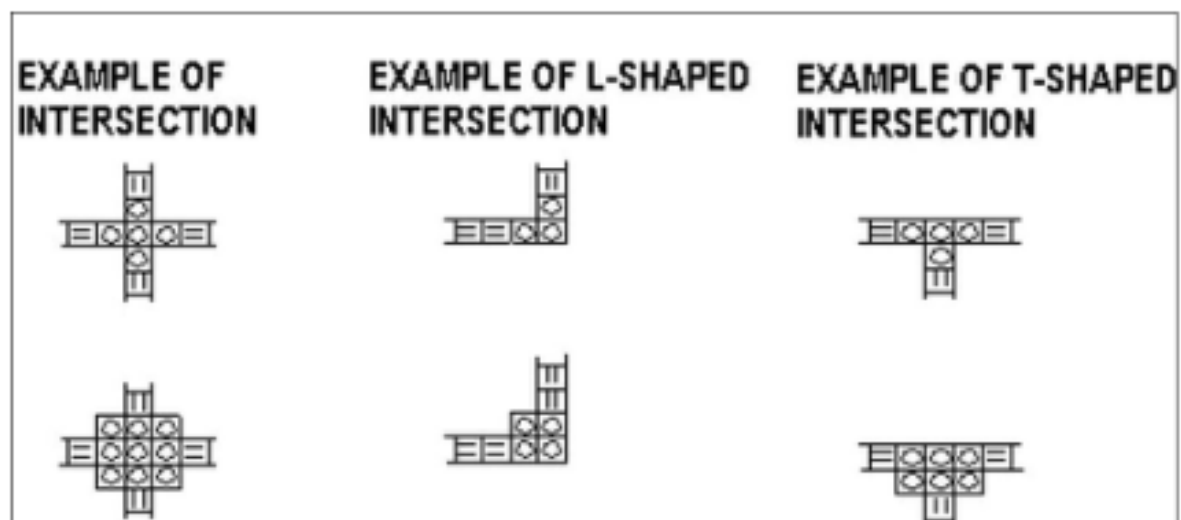

Figure 14 Configuration of Guiding Path and Warning Strip

## 11 Doors<sup>20</sup>

Whatever the type of entrance door, it must be wide enough to accommodate passenger traffic comfortably.

- The recommended minimum clear opening width of an internal door is 900mm minimum.
- Where doors comprise two leaves (i.e. double doors), each leaf should be 900mm min. wide, so that persons carrying large items and wheelchair users do not have to open both leaves.
- Manual doors should incorporate kick plates 300-400mm high to withstand impact of wheelchair footrest (this is especially important where doors are glazed).
- Also be fitted with vision panels at least between 900mm and 1500mm from floor level.
- Be color contrasted with the surrounding wall and should not be heavier than 22N to open.
- Lever handles and push type mechanisms are recommended (photo 1). When a sliding door is fully open, handles should be usable from both sides.
- Where revolving doors or turnstiles are used, an alternative wheelchair-accessible entrance must also be provided.
- A distance of 400mm should be provided beyond the leading edge of door to enable a wheelchair user to maneuver and to reach the handle.
- To ensure maximum clarity for persons with vision impairments, the entrance should be easily distinguishable from its surroundings by the effective use of landscaping, signage, colour (preferably yellow/orange), tonal contrast and tactile surfacing.
- Door hardware should be positioned between 900-1000mm above floor (figure 15).

<sup>20</sup> Access for All, Internal design consideration guidelines, 2012, Samarthyam

- Operable devices such as handles, pulls, latches and locks should:
  - Be operable by one hand
  - Not require fine finger control, tight grasping, pinching or twisting to operate
- Glazed doors and fixed glazed areas should be made visible by use of a clear, colour and tone contrasted warning or decorative feature that is effective from both inside and outside and under any lighting conditions, e.g. a logo, of minimum dimensions 150mm by 150mm (though not necessarily square), set at eye level.

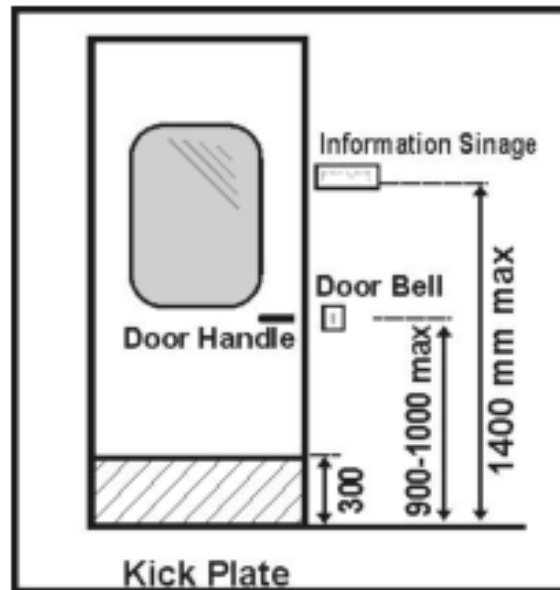

**Figure 15 Position of door hardware**



**Photo 1 Hyderabad Airport**

## 12 Steps & Stairs<sup>21</sup>

- Steps should be uniform with the tread not less than 300mm and the risers 150mm.
- The risers should not be open.
- The steps should have an unobstructed width of at least 1200mm.
- All steps should be fitted with a permanent colour and tone contrasting at the step edge, extending the full width of the step, reaching a minimum depth of 50mm on both tread and riser (figure 16 & photo 2).
- Have continuous handrails on both sides including the wall (if any) at two levels: upper at 900mm and lower at 760mm and extend not less than 300mm beyond the top and bottom step (Figure 17).
- Warning blocks to be placed 300mm at the beginning and at the end of all stairs.
- Nosing to be avoided.
- The staircase should be adequately and uniformly illuminated during day and night (when in use). The level of illumination should preferably fall between 100-150 lux.
- The rise of a flight between landings must be no more than 1200mm.
- There should be no more than 12 risers in one flight run.
- The stair covering and nosing should be slip-resistant, non-reflective, firmly-fixed and easy to maintain.
- Soffit (underside /open area under the stairs) of the stairs should be enclosed or protected.

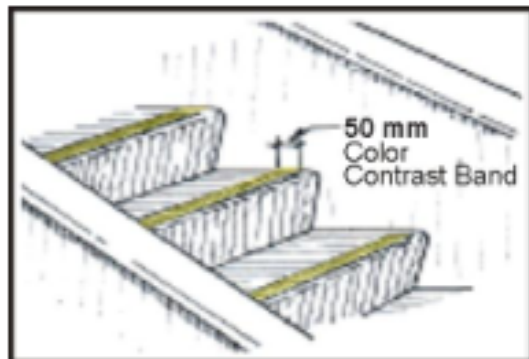

Figure 16 Step edges in contrast colour

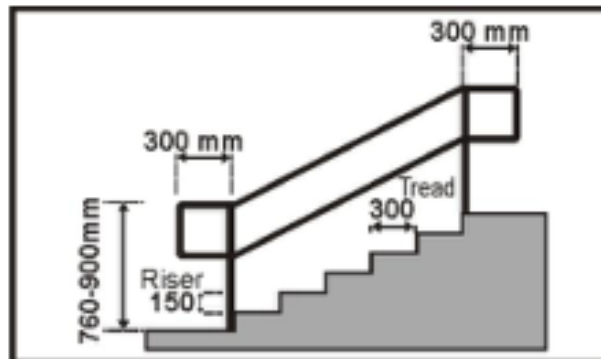
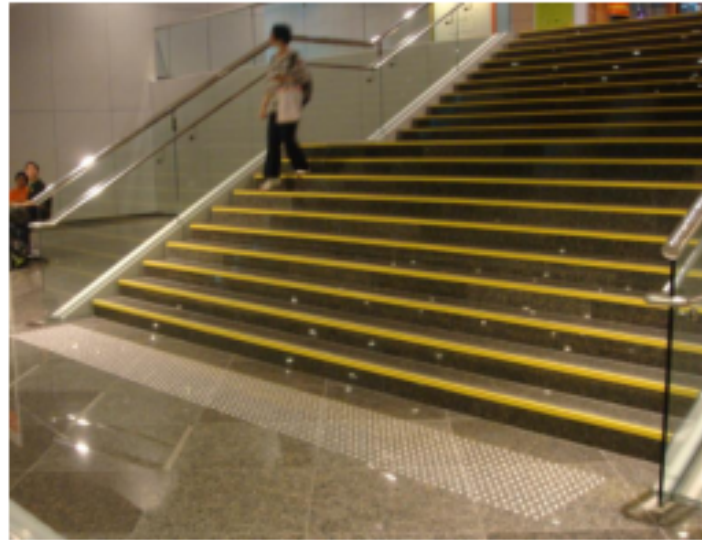

Figure 17 Stairs with handrails

<sup>21</sup> Access for All, Internal design consideration guidelines, 2012, Samarthyam



**Photo 2 Contrast colour step edges, Hong Kong**

#### **14. Handrails<sup>22</sup>**

- Handrails should be circular in section with a diameter of 38-45mm (figure 18) and formed from materials which provide good grip such as timber, nylon or powder coating, matt finish metal finishes.
- The handrail should contrast in colour (preferably yellow/orange) with surrounding surfaces.
- At least 50mm clear of the surface to which they are attached and should be supported on brackets which do not obstruct continuous hand contact with the handrail.
- The handrail should be positioned at two levels- 760mm and 900mm above the pitch-line of a flight of stairs.
- Handrail at foot of the flight of stairs should extend 300mm beyond the stairs in the line of travel and returning to the wall or floor or rounded off, with a positive end that does not project into the route of travel.

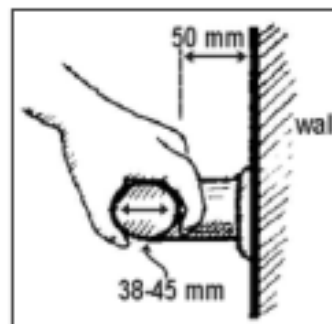

**Figure 18 Knuckle clearance**

<sup>22</sup> Access for All, Internal design consideration guidelines, 2012, Samarthyam

## 15. Ramps<sup>23</sup>

- Ramps gradient should ideally be 1 in 20 and no greater than 1 in 12.
- Width of the ramp should not be less than 1200mm and preferred width is 1800mm.
- The steeper the gradient, the shorter the length of ramp between landings.
- On long ramps, a horizontal resting space should be provided every 6 meters.
- Surface materials should be slip-resistant, non-reflective, firmly-fixed and easily maintained
- The edge of the ramp should have an edge protection with a minimum height of 100mm.
- Landings every 750mm of vertical rise.
- A tapping or lower rail should be positioned so that its bottom edge is no higher than 200mm above ground level.
- Handrails on the ramps should be on both sides at two levels: upper at 900mm and lower at 760mm; both end to be rounded and grouted; extend 300 mm beyond top and bottom of ramp (figure 19).
- A row of tactile warning blocks should be placed 300mm beginning and end of each run.
- Landings should be provided at regular intervals as indicated in the table (Table 1).

**Table 1 Specifications for Ramps<sup>23</sup>**

Level difference	Minimum gradient of Ramp	Ramp Width	Handrail on both sides	Comments
≥ 150 mm ≤ 300 mm	1:12	1200 mm	√	
≥ 300 mm ≤ 750 mm	1:12	1500 mm	√	Landings every 5 meters of ramp run.
≥ 750 mm ≤ 3000mm	1:15	1800 mm	√	Landings every 9 meters of ramp run.
≥ 3000 mm	1:20	1800 mm	√	Landings every 9 meters of ramp run.

<sup>23</sup>

[http://www.urbanindia.nic.in/programme/ud/Research%20Study\\_Building%20Regulations\\_Access%20Standards.pdf](http://www.urbanindia.nic.in/programme/ud/Research%20Study_Building%20Regulations_Access%20Standards.pdf)

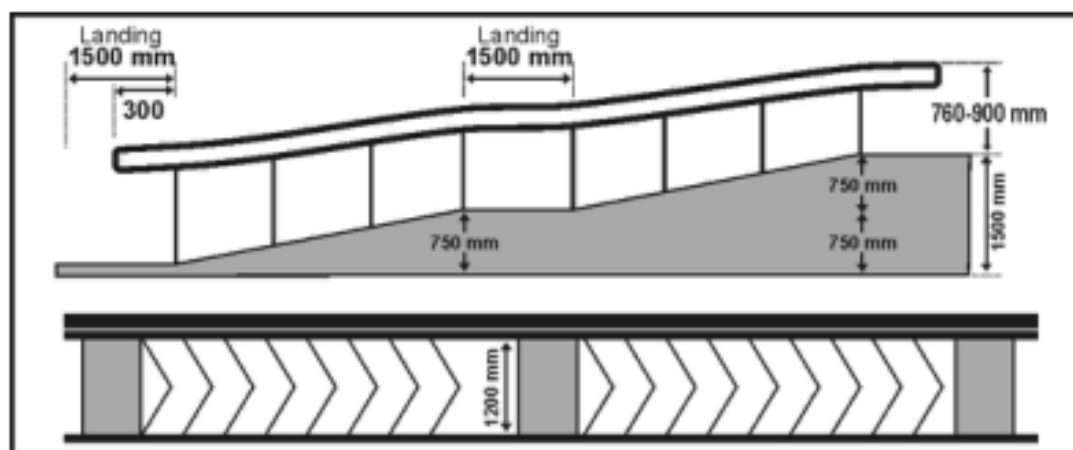

Figure 19 Straight ramp

## 16. Lifts<sup>24</sup>

A carefully designed lift makes a huge contribution to the accessibility of a multi-storey terminal building for persons with reduced mobility and disabilities.

- Lift locations should be clearly signposted from the main pedestrian route and recognizable through design and location.
- The colour and tone of the lift doors should contrast with the surrounding wall finish to assist in their location. Lift doors with metallic finishes such as steel grey and silver should be avoided as they are difficult to identify by persons with low vision.
- The lift lobby shall be of an inside measurement of 1800mm X 2000mm or more. A clear landing area in front of the lift doors of minimum dimensions 1500mm x 1500mm should be provided.
- By making the landing area distinguishable by floor surface and contrast, it will aid location and recognition of core areas. This could comprise a change in floor finish from thin carpet to vinyl/PVC, or cement/mosaic floor to carpet.
- Changes in floor finish must be flushed. There should be no difference in level between the lift door and the floor surface at each level. The gap if unavoidable should not be more than 12mm.
- The floor level/location should be indicated on the wall adjacent to or just above the call buttons, and opposite the lift doors where possible.

<sup>24</sup>

[http://www.urbanindia.nic.in/programme/ud/Research%20Study\\_Building%20Regulations\\_Access%20Standards.pdf](http://www.urbanindia.nic.in/programme/ud/Research%20Study_Building%20Regulations_Access%20Standards.pdf)

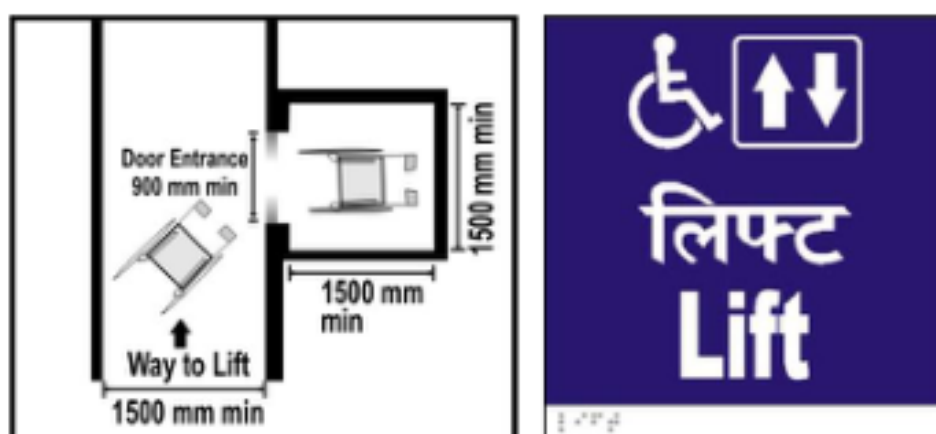

Figure 20 Lift lobby

Figure 21 Lift signage

### 16.1 Lift Dimensions

- Provisions of at least one lift shall be made for the wheel chair user with the following car dimensions:
  - Clear internal depth -1500 mm minimum
  - Clear internal width - 1500 mm minimum
  - Entrance door width - 900 mm minimum

### 16.2 Lift Controls

- The lift call button should be wall-mounted adjacent to the lift and should contrast with wall finish, either by using a contrasting panel, or a contrasting border around the button panel.
- The call buttons should be located within the range 800-1000mm above floor finish.
- Buttons should not be touch sensitive, but should require a light positive pressure.
- Buttons should ideally be large enough to be operable by the palm of the hand if required.
- The control buttons inside the lift should be positioned on the side wall rather than front wall to allow access from the back and front of the lift car, by mobility aid users like wheelchair users.
- In larger lifts, controls should be positioned on both side walls, at least 400mm from front wall and between 800-1000mm above floor level.
- The control buttons should contrast with their surroundings and illuminate when pressed.
- The control buttons should incorporate highly visible tactile embossed (NOT engraved) characters. It is desirable, to repeat the legend in Braille.
- Time of closing of an automatic door should be more than 5 seconds and the closing speed should not exceed .25 meters per second. There should be a provision of sensor enabled closing (figure 22).

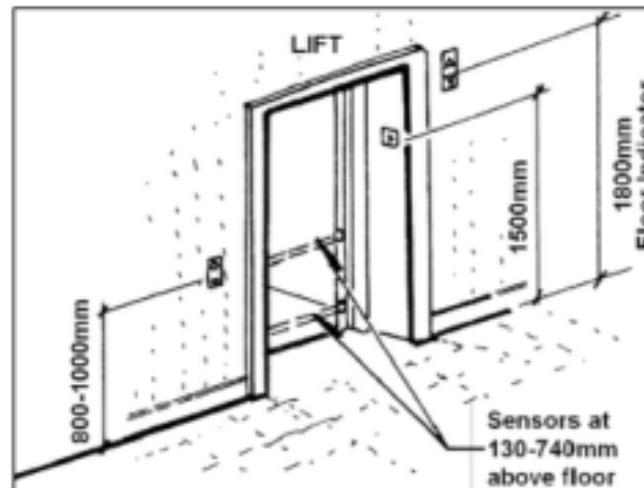

Figure 22 Lift controls

### 16.3 Car Design

- Internal walls should have a non-reflective, matt finish in a colour and tone contrasting with the floor, which should also have a matt, non-slip finish.
- Use of reflective materials such as metal (stainless steel for example) can be problematic in creating sufficient contrast with control buttons, emergency telephone cabinet etc. for persons with low vision and the use of such materials should be avoided wherever possible.
- A mirror (750mm above floor level) on the rear wall can be useful to persons using wheelchairs and other mobility aids should they need to reverse safely out of the lift car or view the floor numbers.
- Internal lighting should provide a level of illumination of minimum 100 lux (approximately 50-75 lux at floor level), uniformly distributed, avoiding the use of spotlights or down lighters wherever possible
- A grab bar should be provided along both sides and the back wall, 900mm above floor level.
- Handrails should be of tubular or oval cross section, in order to be easily gripped and capable of providing support.
- Handrails should be positioned so that there is a clear space behind the handrail to allow it to be grasped i.e. knuckle space should be 50mm.

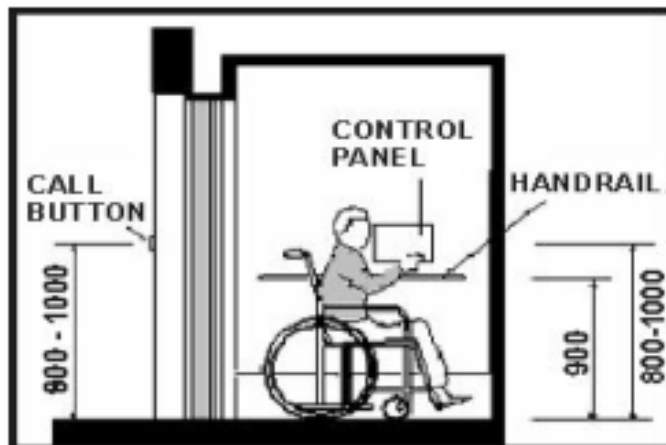

Figure 23 Lift standards

#### 16.4 Information Systems

- Lifts should have both visual and audible floor level indicators.
- Audible systems are also usually capable of incorporating additional messages, such as door closing, or, in the case of an emergency, reassurance (with manual over-ride allowing communication with lift occupants).
- Announcement system should be of 50 decibel.
- The display could be digital or segmented LED, or an appropriate alternative. A yellow or light green on black display is preferred to a red on black display as it is easier to read.

#### 17. Washrooms and Toilets<sup>25</sup>

- All signage of general toilets should be in bold and contrasting colors.
- For persons with low vision and vision impairments pictogram (male pictogram in triangle and female pictogram in circle- figure 24), marked on plates along with Braille & raised alphabets, to be mounted on wall next to door near the latch side, at a height between 1400mm-1600mm.
- Warning strip/ thin rubber door mat to be provided 300mm before and after the toilet entrance.
- Tactile blocks to be provided for urinals, WC and washbasins for persons with vision impairments.

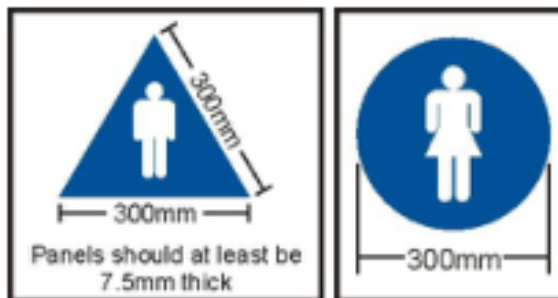

Figure 24

---

25

[http://www.urbanindia.nic.in/programme/ud/Research%20Study\\_Building%20Regulations\\_Access%20Standards.pdf](http://www.urbanindia.nic.in/programme/ud/Research%20Study_Building%20Regulations_Access%20Standards.pdf)

### 17.1 Accessible toilets<sup>26</sup>

- Should have the international symbol of accessibility displayed outside for wheelchair access.
- The toilet door should be an outward opening door or two way opening or a sliding type and should provide a clear opening width of at least 900mm.
- It should have a horizontal pull-bar, at least 600mm long, on the inside of the door, located so that it is 130mm from the hinged side of the door and at a height of 1000mm (photo 3).



**Photo 3 Hong Kong Airport**

#### 17.1.2 WC Compartment Dimensions

- The dimensions of a unisex toilet are critical in ensuring access. The compartment should be at least 2200mm and 2000mm (figure 25). This will allow use by both manual and motorized wheelchair users.
- Layout of the fixtures in the toilet should be such that a clearing maneuvering space of 1500mm x 1500mm in front of the WC and washbasin (figure 25).

#### 17.1.3 Water Closet (WC) Fittings

- Top of the WC seat should be 450–480mm above finished floor level, preferably be of wall hung or corbel type as it provides additional space at the toe level.

---

<sup>26</sup>

[http://www.urbanindia.nic.in/programme/ud/Research%20Study\\_Building%20Regulations\\_Access%20Standards.pdf](http://www.urbanindia.nic.in/programme/ud/Research%20Study_Building%20Regulations_Access%20Standards.pdf)

- An unobstructed space 900mm wide should be provided to one side of the WC for transfer, together with a clear space 1200mm deep in front of the WC.
- WC should be centred 500mm away from the side wall, with the front edge of the pan 750mm away from the back wall. Have a back support. The WC should not incorporate a lid, since this can hinder transfer.
- L-shape grab bar at the adjacent wall and on the transfer side (open side) swing up grab bar shall be provided.
- The cistern should have a lever flush mechanism, located on the transfer side and not on the wall side and not more than 1000mm from the floor.

#### 17.1.4 Grab Bars

- Grab bars should be manufactured from a material which contrasts with the wall finish (or use dark tiles behind light colored rails), be warm to touch and provide good grip.
- It is essential that all grab rails are adequately fixed, since considerable pressure will be placed on the rail during maneuvering. Grab bars should sustain weight of 200kgs minimum.
- A hinged type moveable grab bar should be installed adjacent to the WC on the transfer side (figure 25). This rail can incorporate a toilet tissue holder. A distance of 320mm from the centre line of the WC between heights of 200-250mm from the top of the WC seat. It should extend 100-150mm beyond the front of the WC.
- A fixed wall-mounted L- shape grab bar (600mm long horizontal and 700mm long vertical) on the wall side should be provided. It should be placed at a height of 200-250mm above the WC seat level.

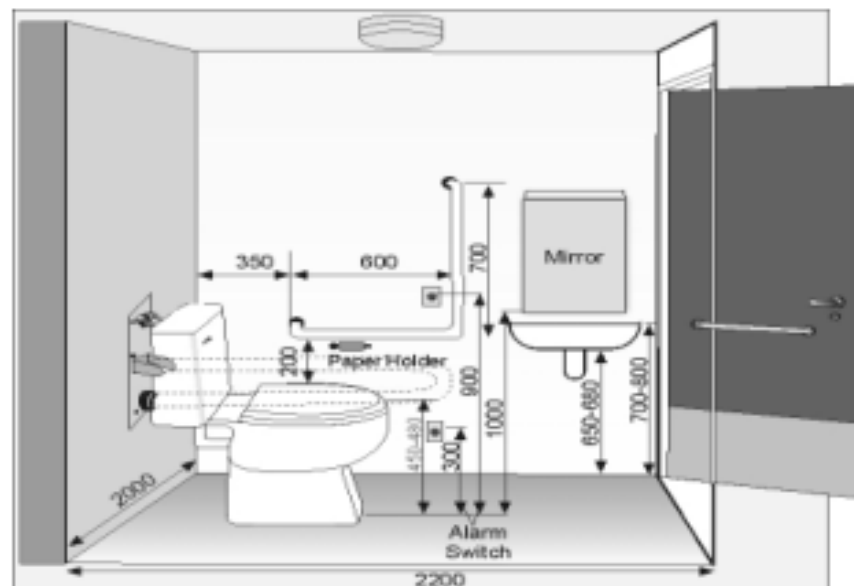

Figure 25 Plan of Accessible Toilet<sup>27</sup>

<sup>27</sup> Access for All, Internal Design Considerations, Samarthyam 2012©

### 17.1.5 Wash Basins<sup>28</sup>

- Wash hand basins should be fitted on cantilevered brackets fixed to the wall.
- The basin should be fixed no higher than 750mm above finished floor level.
- Be of dimensions 520mm and 410mm, mounted such that the top edge is between 800-900mm from the floor; have a knee space of at least 760mm wide by 200mm deep by 650--680mm high (figure 19).
- The position of the basin should not restrict access to the WC i.e. it should be located 900mm away from the WC.
- A lever operated mixer tap fitted on the side of the basin closest to the WC is useful as it allows hot and cold water to be used from a seated position on the WC. The water temperature should be thermostatically controlled at 40<sub>i</sub>-45<sub>j</sub>.
- The hand drying facilities should be located close to the wash hand basin between 1000-1200mm.
- Lever type handles for taps are recommended.
- Mirror's bottom edge to be 1000mm from the floor and may be inclined at an angle.

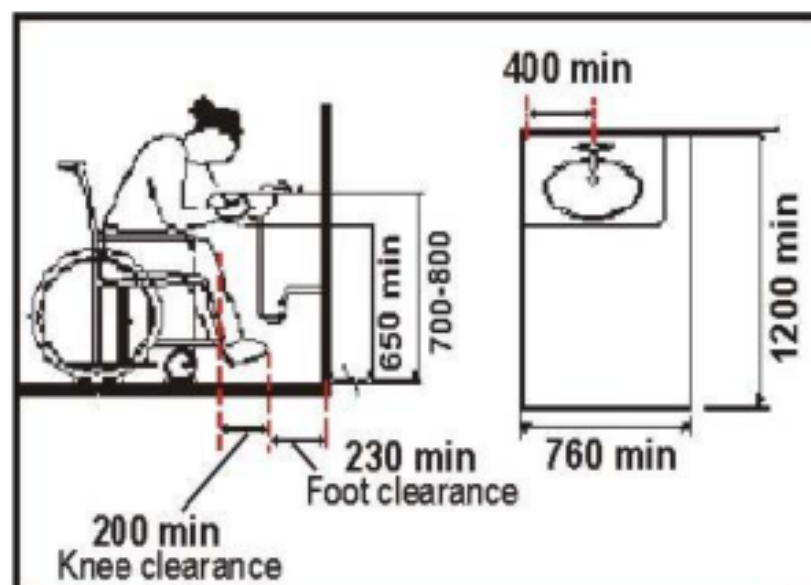

Figure 26 Washbasin standards

### 17.1.6 Fixtures and Fittings

- Contrast between fittings and fixtures and wall or floor finishes will assist in their location. For example, using contrasting fittings, or dark tiles behind white wash hand basins and

<sup>28</sup>

[http://www.urbanindia.nic.in/programme/ud/Research%20Study\\_Building%20Regulations\\_Access%20Standards.pdf](http://www.urbanindia.nic.in/programme/ud/Research%20Study_Building%20Regulations_Access%20Standards.pdf)

urinals, contrasting soap dispensers and toilet roll holders. Contrast between critical surfaces e.g. floors, walls and ceilings helps to define the dimensions of the room.

- Towel rails, rings and handrails should be securely fixed to the walls and positioned at 800-1000mm from the floor.
- The mirror should be tilted at an angle of 30° for better visibility by wheelchair users.
- It should have lower edge at 1000mm above floor finish and top edge around 1800mm above floor finish.
- Hooks should be available at both lower-1200mm and standard heights- 1400mm, projecting not more than 40mm from the wall.
- Where possible, be equipped with a shelf of dimensions 400mm x 200mm fixed at a height of between 900mm and 1000mm from the floor.
- Light fittings should illuminate the user's face without being visible in the mirror. For this reason, most units which have an integral light are unsatisfactory.
- Large, easy to operate switches are recommended, contrasting with background to assist location, at a maximum height of 1000mm above floor finish.
- All toilet facilities should incorporate visual fire alarms.
- Alarms must be located so that assistance can be summoned both when on the toilet pan i.e. at 900mm height and lying on the floor i.e. at 300mm, from floor surface. Alarms should be located close to the side wall nearest the toilet pan, 750mm away from rear wall and at 900mm and 200mm above floor finish.

#### 17.1.7 Signage of accessible washrooms

- All unisex accessible toilets to have access symbol in contrast colours (figure 27). A distinct audio sound (beeper/clapper) may be installed above the entrance door for identification of the toilets.



Figure 27 Signage for accessible washroom

#### 17.1.8 Accessible Urinal<sup>29</sup>

- At least one of the urinals should have grab bars to support ambulant persons with disabilities (for example, crutch users).

<sup>29</sup>

[http://www.urbanindia.nic.in/programme/ud/Research%20Study\\_Building%20Regulations\\_Access%20Standards.pdf](http://www.urbanindia.nic.in/programme/ud/Research%20Study_Building%20Regulations_Access%20Standards.pdf)

- A stall-type urinal is recommended.
- Urinals shall be stall-type or wall-hung, with an elongated rim at a maximum of 430mm above the finish floor. This is usable by children, short stature persons and wheelchair users.
- Urinal shields (that do not extend beyond the front edge of the urinal rim) may be provided with 735mm clearance between them.
- Grab bars to be installed on each side, and in the front, of the urinal (figure 28).
- The front bar is to provide chest support; the sidebars are for the user to hold on to while standing.

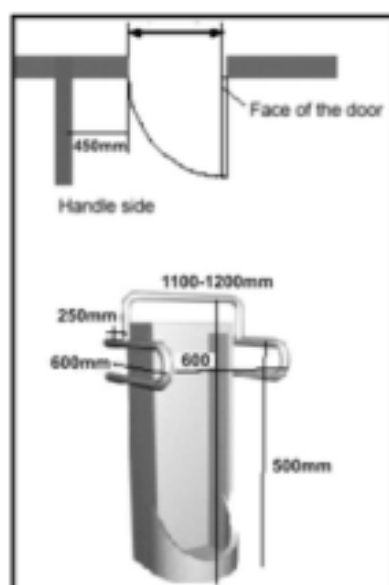

**Figure 28**

## 18. Drinking water units<sup>19</sup>

- Drinking fountains or other water-dispensing means shall be accessible to and usable by persons with disabilities.
- Drinking water fountains or water coolers shall have up front spouts and control (photo 11 & 12).
- Drinking water fountains or water coolers shall be hand-operated or hand and foot-operated.
- Conventional floor mounted water coolers may be convenient to individuals in wheelchairs if a small fountain is mounted on the side of the cooler 800mm above the floor.
- Fully recessed drinking water fountains are not recommended.
- Leg and knee space to be provided with basin to avoid spilling of water (figure 29). This allows both front and parallel access to taps for persons using mobility aids like wheel chair, crutches etc.

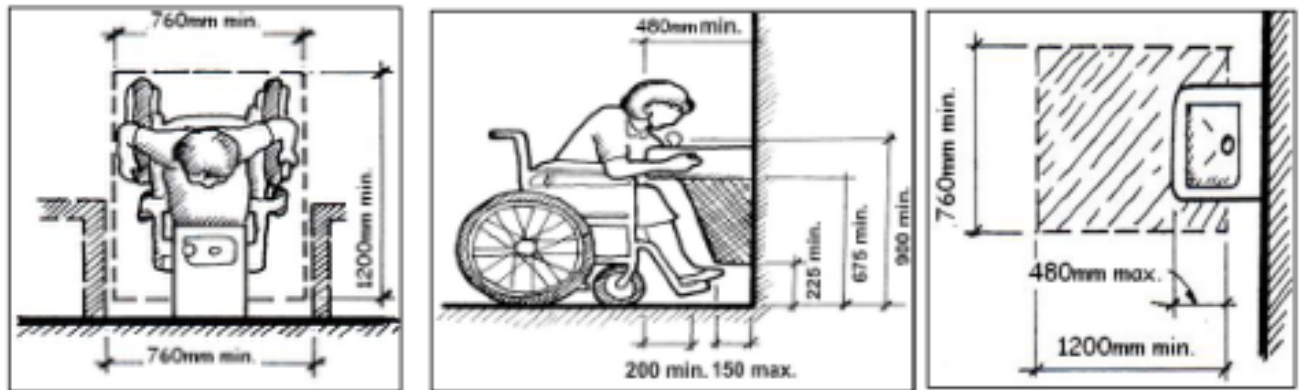

Figure 29

## **Security Process**

### **Background**

Security checks are concern for Persons with Disabilities because security personnel are not adequately training in handling persons with disabilities. While there is no doubt that security is paramount, the dignity of persons with disabilities must not be violated during the security process, particularly when it is possible to conduct security screening while completely respecting the rights of persons with disabilities. Some of the problems faced by passengers with disability include persons in wheelchairs being asked to stand up, people being asked to remove their clothes so that their prosthetic limbs/calipers can be touched by the security personal etc.

Given below are the best practices to be followed during the security process

### **Interaction with persons with disabilities**

- a) Screeners shall be trained to:
- b) Be courteous and friendly
- c) Treat everyone fairly and equally
- d) Be respectful throughout the screening process
- e) Assess the needs of person to be screened
- f) Ask, and not assume the type of assistance needed
- g) Provide appropriate screening options.

### **Screening Process**

1. For passengers using wheel chair or other mobility aid the screening officer shall advise of the screening process that will be required prior to entering the Departure Lounge. Passengers are to advise the screening officer of their condition and if required, request separate screening to avoid passing through a metal detector.
2. The Screening points should have, full body scanners, chairs and walking aids for semi ambulant walking-aid user.
3. Full body scanners should be used for passengers using their own wheelchairs and should not be asked to stand up or transfer to wheelchairs provided by the airport. A wheelchair user unable to move, raise hands, etc. shall be subjected to secondary screening and shall undergo a pat down (frisk search) of the person by a screening officer of the same gender. Screening officers shall obtain consent to conduct a frisk search. Before a frisk search is

carried out, the screener shall offer the use of a private search room. Private screening rooms shall be available upon request.

4. For passengers who are blind/low vision the screening staff shall:
  - i) offer screening options to stand or sit for primary screening;
  - ii) assist persons through the Walk-Through Metal Detector (WTMD);
  - iii) provide an option for private screening;
  - iv) where a physical search of personal belongings is required, replace all items where they were originally located;
  - v) make certain that an assistance animal, such as a guide dog, is not separated from a person during screening;
  - vi) shall make or put up identification mark on the baggage;
  - vii) identity card or badge No. of the "assistance" provided to escort the passenger who are blind/low vision must be communicated in writing.
  
5. For passengers with Hearing Impairment, the following techniques can be used:
  - i) speak in a normal tone and pace, in a clear and concise manner;
  - ii) use hand signals and gestures to help express spoken direction (pointing and nodding);
  - iii) maintain eye contact at all times and speak directly to the person with the impairment;
  - iv) point out visual alarms by physical indication; and
  - v) if communication difficulties persist, screening officers shall use written instructions to communicate to the guest.
  
6. For passengers with hidden disabilities the following techniques can be used:
  - i) If requested, allow escort to assist, and go through security check, with person with disability of opposite sex.

\*\*\*

**Annexure 5**

**Funding of costs with respect to implementation of regulations**

It is acknowledged that there will be substantial costs in implementing of the proposed regulations. The issue of meeting these costs is of critical importance. It is also under no debate that passengers must not be charged for the implementation of the regulations. It is also recognized that under the United Nations Convention on the Rights of Persons with Disabilities, which India has signed and ratified, the primary obligation of funding such activities and implementation of regulations to bring about equality and non-discrimination is on the country. In addition to the above, under the United Nations Convention on the Rights of Persons with Disabilities, the country also has obligation to ensure that private entities that offer facilities and services which are open or provided to the public take into account all aspects of accessibility for persons with disabilities. Given these parameters the following are some options for recovering the costs of implementation of the regulations in order of priority. With a view to ensuring, in particular, that the charges levied on an airline (if any) are commensurate with the assistance provided to persons with disabilities and persons with reduced mobility, and that these charges do not serve to finance activities of the airport other than those relating to the provision of such assistance, the charges should be adopted and applied in full transparency.

**Option 1**

Airport operators and airlines must bear the cost of providing the services to be prescribed under the proposed regulations. This is the current scenario under the existing CAR. Since under the proposed structure given in paragraph 2.5 of this report, most of the responsibilities lie with the airports, the airports will incur the bulk of the expense. The implementation of these regulations must be seen in the same vein as the provision of amenities such as clean toilets or air conditioning to other passengers, which are all provided free of cost to the passengers.

**Option 2**

A charge may be collected from each passenger for providing facilities to PRMs. This could be an additional charge or a part taken from the Passenger Service Fee (PSF) charged by the airports. A mechanism should be evolved to pool this fund which may

then be distributed to the airlines and airports based on the expenditure incurred for providing facilities.

**Option 3**

The Ministry of Social Justice and Empowerment or the Ministry of Civil Aviation must fund the implementation of the regulations.

\*\*\*

**Annexure 6**

**Implementation Plan**

The Ministry may fix up a time frame for approving/modifying/disapproving the recommendations made in this report.

A time bound schedule is to be drawn up by the Ministry to revise the CAR, to incorporate the approved recommendations.

The implementation of the approved recommendations need not be at all airports simultaneously. The airports in the country may be categorized as A,B,C etc based on the movement of the number of passengers requiring assistance and implementation of the provisions of the revised CAR can be taken up from the category having the largest number of such passengers.

It is important that all airlines, including non-scheduled air transport operators and all airports take action to implement the recommendations contained in this report. The airlines, operators and airports must also declare their policy on facilities provided to PRMs by publishing on their respective websites in a clear and unambiguous manner.

\*\*\*

Annexure 7

**Minutes of the meeting on the rights of passengers with disability and reduced mobility held on 12.03.2012 under the Chairmanship of Shri G. Asok Kumar, Joint Secretary, M/o Civil Aviation.**

A meeting was held under the Chairmanship of Shri G. Asok Kumar, Joint Secretary, M/o Civil Aviation (MoCA) on the rights of passengers with disability and reduced mobility was held on 12.03.2012 in the Conference Hall of Ministry of Civil Aviation.

2. List of the participants is enclosed.

3. At the outset, the Chairman welcomed the participants. Initiating the deliberations, Chairman informed that the purpose of meeting was to get feedback from representatives of differently-abled-people/persons-with-disabilities on the problems they were facing in undertaking air travel and suggestions on how to improve the facilities to them to make their travel more convenient. He said that a Civil Aviation Requirement(CAR) on "carriage of persons with disability and reduced mobility by air" has been issued in 2008, as a first attempt to address the issue. In view of the improved guidelines adopted in other developed countries and resolution of UNCPRD, MoCA is considering to make modifications in the CAR. He further stated that the Ministry is formulating a new Civil Aviation Policy, in which there is a portion related to facilities to passengers with reduced mobility. He requested the participants to forward their views so that the issue can be incorporated in the draft civil aviation policy.

He said that the inconvenience faced by persons with disabilities right from the stage of booking of tickets; arrival at the airport; checking-in; issues

related to location and design of facilities like toilets, wheel chairs, check-in counters etc; issues at security checking; boarding of aircraft; seating in aircraft; disembarking; collection of luggage etc could be discussed and suitable solutions suggested for improvements.

4. The representatives of various organizations related to disable persons welcomed the initiative of the Ministry to call the meeting to discuss the issues related to the problems faced by them during air travel. They wanted proper enforcement of provisions contained in the existing Civil Aviation Requirements. They maintained that unless punitive actions taken against the violators, these guidelines are of no use. The Chairman assured that the DGCA, which is the regulating agency, would definitely take appropriate steps for the effective implementation of the CAR.

5. The representatives desired that the term disability may be redefined in the CAR as per the latest definitions internationally accepted. There are cases of hidden disabilities which require adequate consideration.

6. They wanted more sensitization on the subject for the staff at the airport and in the aircraft. The Chairman suggested that guidelines can be issued to the airlines and airport operators to include slots for appropriate training on sensitization of staff on handling disabled people in their mandatory periodic trainings. The course content can be developed with the help of the various groups who are involved in the welfare of disabled people.

7. Representatives of organizations stated that it often occurs that the information submitted by them to travel agents/booking counter not available with the airlines and it causes problems. Further they also submitted that various airlines are using different

software/forms, which makes them difficult to provide the overall information of disability. They said that Air India has better facility in this regard and the same software/form should be used by all other airlines. The web page of the airlines should be having standard look and format while dealing with the issues of the disabled. They should be comply with the WCAG 2.0 which deals with the provisions for people with visual disability and muscular disability to access websites. At the time of booking itself, the airlines should be able to capture the special requirements required to be provided by airlines to the disabled persons and take actions accordingly while checking-in and boarding.

8. They said that in foreign countries, it is the airport operators that provide all assistance for the people with disabilities, where as in India it is left to the airlines. Representative of AAI informed that they are providing the required infrastructure and it the responsibility of airline for proper care of disable passengers. The Chairman assured that in the guidelines proposed to be issued the responsibility will be clearly defined.

9. The group wanted appropriate accessories to be provided to them at the airports. Some of the wheel chairs provided now are unsafe and not properly designed. The chairman said that this issue of getting properly designed accessories would be addressed.

10. Representatives desired that there should be a designated place/counter in the airport for disabled persons to come first and from there they can be redirected with proper assistance to the counters of the airlines. The designated person there should be trained to deal with the issues of different disabilities and sensitive to their needs.

Proper signage should be done at these places for easy identification. Even if it is not manned all the time, a bell or intercom be provided there so that when assistance is needed, it can be used to contact this designated trained person. People with hearing disability wanted visual alarms to be given in case of emergency. They desired that the designated person may also be trained in sign language to communicate with them.

11. It is seen that in aircrafts, persons with disability are being provided seats near toilet, which is a welcome step but in some cases there are no such requirement and for these cases there should be option for them to choose the seats.

12. The representatives desired stated that a procedure being followed in other countries that announcement was made for preferential boarding of disabled persons. They desired that this procedure should also be adopted in India.

13. The representatives also raised the issue that some type of disabled persons not allowed to travel. They desired that such decision should not be arbitrary and a standard, transparent procedure should be developed in this regard.

14. The representatives wanted the personnel manning the security check in be sensitized about the special needs of the disabled persons, checking of their personal accessories/equipments etc.

15. The Chairman assured that the issues raised by various organizations would be taken addressed earnestly.

16. After deliberations, It was decided that a Committee will be constituted under the chairmanship of JS, MoCA with representatives of DGCA, AAI, anyone of private airport operators, BCAS, one or two airlines and two organizations involved for working of

persons with disability/reduced mobility. The committee will look into these aspects discussed in this meeting, best practices in the world on the matter, latest UN/ICAO guidelines etc dealing with persons with disabilities and come with a report for the appropriate modifications of the CAR, suggestions for the improvement of designs of websites, accessories and facilities/infrastructure etc specially meant to facilitate comfortable air travel for the persons with disabilities.

16. The meeting ended with Vote of Thanks to the Chair and the representatives.

\*\*\*\*\*

**List of Participates**

- |     |                                   |   |
|-----|-----------------------------------|---|
| 01. | Shri G. Asok Kumar, Jt. Secretary | Joint Secretary   |
| 02. | Shri Sarwesh Kr. Arya,            | Under Secretary,  |
| 03. | Shri Rajendra Dhoke,              | Addl. CoSCA, BCAS   |
| 04. | Shri Lalit Gupta,                 | DDG, DGCA   |
| 05. | Shri G. K. Chaukiyal              | Member (Ops), AAI   |
| 06. | Kalpna Sethi                      | ED (Planning), AAI  |
| 07. | S.C. Sharma                       | ED (Planning), AAI  |
| 08. | M.T. Baig                         | ACS(LA), BCAS   |
| 09. | Sanjeev Sachdeva                  | Samarthyam  |
| 10. | Rahul Cheran                      | Inclusive Planet Centre for<br>Disability Law and Policy.   |
| 11. | Merry Barua                       | Action for Autism and Austsm<br>Spectrum Rights Alliance.   |
| 12. | Shekhar Boarker,                  | Board Member, National Trust<br>/ADAPT Mumbai   |
| 13. | A.S. Narayanan                    | National Association of the Deaf<br>DRG   |
| 14. | A.K. Sivanandan                   | Vice President (PR)/ Jet Airways.   |
| 15. | Shanti Auluck                     | Director (Hon)/ President Muskan,<br>an NGO working with people with<br>intellectual Disability &<br>Families/DRG |
| 16. | Kanchan Pamnani                   | DRG   |
| 17. | Reshma Valliappan (on DRG         |   |

behalf of Naajmi & other  
persons with psycho – social  
disability)

- |                    |  |
|--------------------|--|
| 18. Amit Kapoor    | Jet Airways  |
| 19. Shivam Gupta   | DRG  |
| 20. Shilpi Ganguly | National Centre for Promotion of<br>Employment of disabled People. |
| 21. Anurag Goyal   | Terminal Ops./DIAL.  |

**Minutes of the 1<sup>st</sup> meeting of the Committee constituted to review the existing guidelines for carriage of persons with reduced mobility/disability held on 10.04.2012 under the Chairmanship of Shri G. Asok Kumar, Joint Secretary, M/o Civil Aviation.**

The 1<sup>st</sup> meeting of the Committee constituted to review the existing guidelines for carriage of persons with reduced mobility/ disability was held under the Chairmanship of Shri G. Asok Kumar, Joint Secretary, M/o Civil Aviation held on 10.04.2012 in the Conference Hall of Ministry of Civil Aviation.

2. List of the participants is enclosed.
3. At the outset, the Chairman welcomed the participants. Initiating the deliberations, Chairman informed that in view of deliberations made in the meeting held on 12.03.2012 on the rights of passengers with disability/reduced mobility, it has been decided to constitute a Committee to examine the existing CAR in light of international best practices and suggest improvements in infrastructure meant to facilitate comfortable air travel for the persons with reduced mobility/ disability.
4. Representative of DGCA informed that a meeting was held in the DGCA with the airlines alongwith the three persons who have complained against airlines for misbehavior, namely, Mohd. Asif, Mr. Rahul Cherian and Ms. Jeeja Ghosh. He further mentioned that detailed presentation was made in the meeting on the problems faced by the disabled at the time of air travel, and the facilities required from the Govt. to facilitate comfortable air travel for them. He further informed that airlines were asked to familiarize their officer/staff with the existing CAR provision on facilities to be provided to passengers with reduced mobility/disability. The airlines were also asked to prominently display the facilities offered by them for the passengers with reduced mobility/disability on their website.

5. The Chairman mentioned that the CAR needs to be modified to facilitate comfortable air travel from the point of entry in the airport, till the point of departure from the final destination apart from ensuring hassle free bookings of tickets through the website, of the airlines. He further desired that the Report of the Committee should incorporate both, the needs of the persons with disability/reduced mobility and the short term and long term solutions to the same.

6. Shri Rahul Cherian submitted that in view of the fact that at present there is no redressal mechanism defined in CAR a complaint and redressal mechanism should also put in place in the Ministry. He further submitted that the role of DGCA in the complaint and redressal mechanism should also be specified,

7. The Chairman informed that the Govt. is in process of finalizing the Civil Aviation Policy which, inter-alia, will cover various aspects like airport issues, cargo, and also issue relating to disabled and other passengers.

8. Mr. Mittal desired that the report of Committee should also be considered in the proposed CAP document. He further submitted that on the lines of EU regulation, the airport managers should be empowered to take action on complaints and make reports to the DGCA/Ministry.

9. It was also discussed in the meeting that though the airport operators are providing space/infrastructure, but since the details of passengers are available only with the airlines, they are to be made responsible to provide the facilities to the passengers through the Ground Handling Agencies as per their Memorandum of Understanding. The Airport Operator does not come into the picture. It was also informed that in other countries it is the airport operator who is providing the facilities at a nominal charge. The Chairman was of the view that since the airport operators are providing infrastructure, they should be made responsible for providing facilities at the airport and the airlines should be responsible for providing facilities in flight. He further submitted that for the services, airport operator may suitably charge the airlines. He desired that there should be a clear cut distribution of responsibilities in this regard. He viewed that there are so many benefits of assigning a single authority to provide

facilities to passengers as it will standardize the facility, facilitate training of the manpower to sensitize them to the problems of the passengers and enable optimum utilization of resources.

10. The issue of Wheel Chair, ambulift and ramp facilities were also raised. Regarding wheel chairs, the representative of DGCA informed that instructions had been issued to the airlines to allow the disabled passengers to use their own wheel chair provided that the same can be adjusted in the available space, and in the case of folding wheel chairs, the same be allowed to be carried with the passenger.

11. The Chairman desired that three smaller Groups may be formed to finalize the report. It was decided that the issues like review of existing CAR; study of best practices in the world, latest UNO/ICAO guidelines on the issue; allocation of responsibilities between the airlines and airports; action items for airports, airlines and other stakeholders and complaint redressal mechanism will be looked into by the Group volunteered by Shri Rahul Cherian with Ms. Anjlee, Mr. Sudhakar Borker and Mr. Mittal as members. The issue like security process/CISF and physical accessibility may be looked into by a Group volunteered by Ms. Anjlee and issues like improvement of design of websites, accessories and facilities/infrastructure; areas for training and sensitization of the airline/airport operators and Standards for equipment at airports will be looked into by third Group volunteered by Ms. Shivani. The Chairman also directed that each group may nominate representatives from airlines and airport operators in their group, if they required.

12. The Chairman desired that the Group members may remain in contact with each other through e-mails to exchange their views and by 28<sup>th</sup> April 2012 they may compile and submit the report to the Committee for consideration in their next meeting. The compiled report may be emailed to the Ministry on the email address [Dtsec.moca@nic.in](mailto:Dtsec.moca@nic.in) or [skarya.moca@nic.in](mailto:skarya.moca@nic.in).

13. The meeting ended with Vote of Thanks to the Chair and the representatives.

\*\*\*\*\*